

Concrete Maturity

From Theory to Application

FOREWORD

Concrete is one of the oldest, most versatile and widely used construction materials throughout the world. Despite its widespread use, one of the limiting factors when using concrete is predicting the time needed to reach design strength at a given time. Architects, engineers, ready-mix providers, and specifiers alike are constantly looking for ways to speed the critical path to placing, finishing and putting into service concrete structures. The use of concrete maturity has emerged to become the champion of concrete strength prediction.

The groundwork of Concrete Maturity: From Theory to Application has been prompted by the fact that many architects, engineers, concrete contractors, and concrete providers lack standardized and preliminary concrete maturity training. The authors have simplified the subject matter for those having a desire to save both time and money on concrete jobsites. The reader will find references to ASTM C1074 as well as other worldwide specifications and standards on predicting concrete strength with the maturity method. Familiarity with this standard is warranted for using the concrete maturity method to ultimately make in-depth decisions in the laboratory and the field.

This particular book has been referred to by many in the industry as a convenient and direct reference for all things concrete maturity, to include: theory, calibration, application, and case studies. In preparing the material for this book, the authors had in mind its use as a textbook for the junior engineer, as well as a book to be used as a resource for concrete jobsite application. Simple and concise explanations of the theory of concrete maturity is included. In addition to the usual logic, the authors included sufficient theory underlying the principles of calibration and implementation. Both are presented in basic practices to ensure a thorough knowledge of the fundamental mechanisms involved in the employment of concrete maturity. A major portion of this book contains case studies that illustrate different modes of concrete maturity implementation. No other books, tables, or charts are required when using this book as a practical reference on concrete jobsites.

Concrete Maturity - From Theory to Application

Overall, Concrete Maturity: From Theory to Application accomplishes one key goal: to convey the simplicity of using the concrete maturity method as a predictive tool on construction sites. The authors have pooled decades of academic research and operational experience to deliver a concise message on this innovative method. The knowledge ascertained from this book serves as the fundamental education for applying concrete maturity on construction sites.

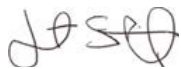

Jon S. Belkowitz, PhD

Director of Research and Development

Intelligent Concrete, LLC

PREFACE

Measuring the compressive strength of concrete is one of the major challenges faced by the construction industry. In examining the concepts of concrete strength and maturity, those affected have an opportunity to optimize critical construction operations and see economic benefits. In *Concrete Maturity: From Theory to Application* you will learn about the concept of concrete maturity, the impact of maturity on concrete strength, and the benefits of understanding maturity throughout the duration of a project.

In chapter one we explore current methodologies in place to measure concrete strength, such as the pullout test, drilled core test, cast in place cylinders, and more. Chapter two introduces you to the maturity concept and discusses the use of field cylinders to monitor the compressive strength of concrete. In chapter three we discuss various advancements in monitoring and computing technologies used for measuring concrete temperature, strength, and maturity for both wired and wireless technologies. Chapter four explores various equations which have been proposed to calculate the maturity of concrete. This includes the temperature-time factor, equivalent age, and the concept of weighted maturity. Calibration and the strength-maturity relationship in regard to concrete mix is discussed in chapter five. In chapter six we outline the use of maturity/temperature sensors on site, which are installed in order to monitor the in-place strength of concrete. Furthermore, we provide advice regarding where such sensors should be mounted on a structure. Chapter seven discusses the economic benefits of using maturity on a construction project and the resulting savings in time, labor, and materials. In chapter eight we explore various case studies of companies and projects that have implemented Giatec Scientific's SmartRock wireless sensors and mobile app on their jobsite. This includes an examination of the various critical information which is available to concrete producers, contractors, and business owners who have used these sensors and have seen an increase in profitability as a result.

Giatec Scientific Inc. would like to thank Walter Flood, Principal Engineer of Flood Testing Labs Inc., and Greg McKinnon, Operations Manager at Stoneway Concrete, for their contribution to this project.

Concrete Maturity - From Theory to Application

Copyright © 2018 Giatec Scientific Inc.

All rights reserved.

Authors: Sarah De Carufel, Andrew Fahim, Pouria Ghods, Aali Alizadeh

Reviewers: Walter Flood (Flood Testing Laboratories Inc.), Greg Mckinnon (Stoneway Concrete)

Editors: Alicia Hearn, Roxanne Pepin

Design and Layout: Katie Roepke

1st Edition

Ebook ISBN: 978-1-9994762-0-5

Global Headquarters

245 Menten Place, Suite 300

Ottawa, Ontario

Canada

K2H 9E8

info@giatec.ca

www.giatec.ca

CONTENTS

1 Concrete In-place Strength Measurement	8
1.1 Rebound Hammer (ASTM C805).....	10
1.2 Penetration Resistance (ASTM C803)	10
1.3 Ultrasonic Pulse Velocity (ASTM C597)	11
1.4 Pullout Test (ASTM C900)	11
1.5 Drilled Core (ASTM C42)	12
1.6 Cast-in-Place Cylinders (ASTM C873)	12
1.7 Maturity (ASTM C1074)	13
2 Introduction to Maturity	15
2.1 What is Concrete Maturity?.....	17
2.2 Cylinders vs. Maturity.....	18
2.3 Standards	20
3 Monitoring System	22
3.1 Wired System	22
3.2 Wireless Technologies	24
4 Calculation Methods	26
4.1 Temperature-Time Factor	26
4.1.1 Datum Temperature Calculation.....	30
4.1.1.1 Rate Constant (K-value).....	30
4.2 Equivalent Age	31
4.3 Weighted Maturity	32
5 Calibration	35
5.1 Calibration Test Procedure	37

1 Concrete In-Place Strength Measurement

Early, rapid, and accurate in-situ estimation of the compressive strength of concrete is one of the major challenges for the concrete industry. A practical solution for such challenges can prevent multi-million dollars of extra annual investment for the construction industry and owners of civil structures. Annual global production of cement in 2017 was estimated to be around 4 billion metric tons ^[47], the largest producers being China, India, and the United States. Consumption in the United States was around 86 million metric tons in 2017 ^[47].

An accurate in-situ estimation of the compressive strength provides the opportunity to optimize critical construction operations, such as formwork removal time, opening a bridge to traffic, prestressed cable tensioning time as well as, optimizing the mix design. The optimization of mix design affects the consumption of raw materials (e.g. cementitious materials and aggregates) and alternative materials (e.g. chemical admixtures). Considering the high volume of global consumption of concrete, this could, in turn, effectively reduce CO₂ emissions, labor and project costs, as well as decrease project completion time with significant financial benefit.

In the large majority of construction sites, field-cured concrete samples are casted and cured according to the ASTM C31^[8]. These samples are then tested for compressive strength (ASTM C39^[9]) at various stages during the first week after concrete is poured. This is done in order to make a decision on critical operations (e.g. formwork removal, post-tensioning, curing, opening roads to traffic, and saw cutting, etc.). Usually, if the concrete reaches 75% of its designed strength, the structural engineers allow for the striping of forms. The problem, however, is that in most cases only one specimen is crushed for strength estimation. This is not necessarily accurate because one cylinder does not represent the entire concrete pour

Concrete Maturity - From Theory to Application

for strength approval. In addition, there is a typical delay in decision-making due to the time required for obtaining and communicating compressive strength results. This adds to the cost of construction and decreases the efficiency of the construction site; which is already faced with issues concerning labor shortage. Such approaches to compressive strength evaluation may cause contractors to make conservative decisions, face more complicated technical problems (e.g. delay in formwork stripping, unnecessary long-term curing and surface protection), and spend more financial resources.

Although alternative methods exist to measure in-place strength, there is a traditional resistance to utilizing them for most concrete projects. With the exception of specific projects, the concrete industry shows interest in this commonly used compressive strength test. This is mainly attributed to lack of expertise, convenience, and accuracy, as well as upfront costs or calibration requirements. A large variety of in-place measurement techniques have been developed, and are still being developed, some more accurate or easy to use than others.

1.1 Rebound Hammer (ASTM C805)

Rebound hammer method^[16], also known as the Schmidt Hammer method, is a test conducted on the surface of the concrete which measures the rebound distance of a hammer. The hammer then impacts a plunger that is placed on the concrete surface using a spring release mechanism (Figure 1-1). The result obtained from the rebound hammer test is scaled from a value of 10 to 100. The hammer number obtained can be correlated to a strength value previously calibrated with cored cylinders. Even though this technique is very simple to use on site, there are many drawbacks that make it subjective. For example, the rebound hammer test results can be affected by surface conditions (wet vs. dry), the presence of large aggregates below the test location, carbonation, frozen concrete, shallow reinforcements, etc.

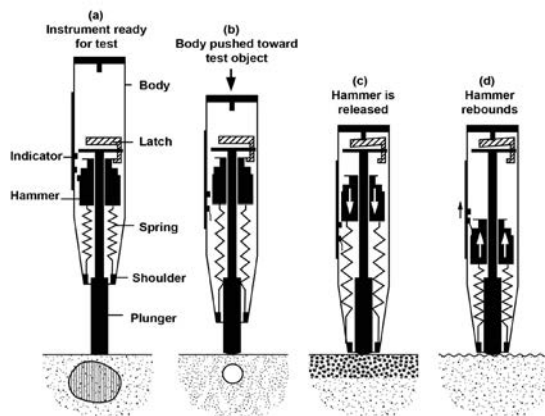

Figure 1-1: Rebound hammer test ^[3]

1.2 Penetration Resistance (ASTM C803)

To complete a penetration resistance^[15] test, the surface of concrete is exposed to a small projectile that is driven in the concrete (Figure 1-2). The penetration of the projectile or depth of the hole can be correlated to the in-place concrete strength using a pre-established relationship. This method is affected by surface condition, type of form used, aggregate type, etc.

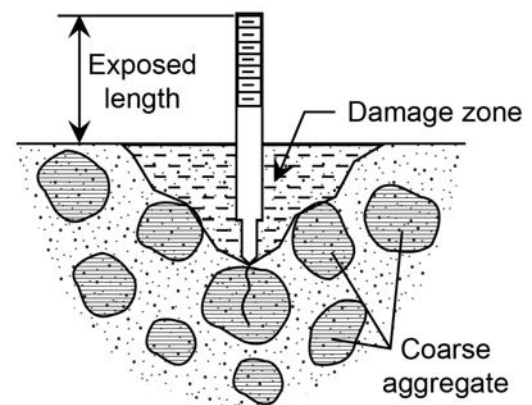

Figure 1-2: Penetration resistance test ^[3]

1.3 Ultrasonic Pulse Velocity (ASTM C597)

The ultrasonic pulse velocity^[14] method determines the velocity of propagation of a pulse of vibrational energy through concrete (Figure 1-3). The pulse velocity can be correlated to elastic modulus and the density of the concrete. Since elastic modulus and strength are not linearly related, the correlation is not linearly dependent. This technique is highly influenced by the presence of reinforcement as well as aggregate and moisture. This method is also applicable to assess the quality and uniformity of concrete, as well as the availability of cracks and voids.

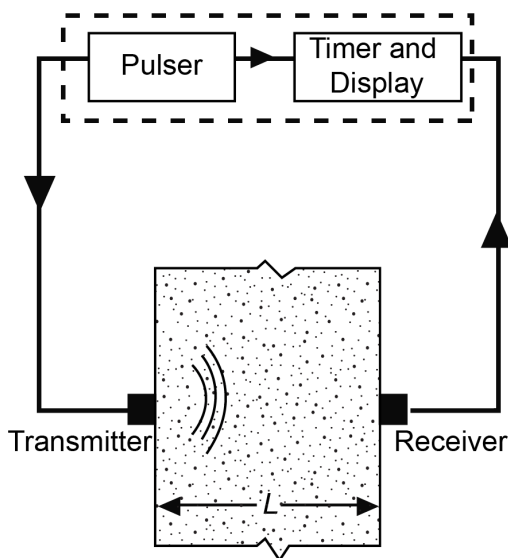

Figure 1-3: Ultrasonic pulse velocity test^[3]

1.4 Pullout Test (ASTM C900)

The pullout test^[18] is a technique that can be used on new or old constructions. The main principal behind this technique is to pull the concrete using a metal rod that is cast in place or post-installed in the concrete (Figure 1-4). The pulled conical shape, in combination with the force required to pull the concrete, can be correlated to the compressive strength. This is done by using an established relationship, depending on the measurement system in place. This method is a destructive method that usually requires a large number of test samples at different locations before obtaining relevant results and can have a relatively high variability. Overall, this test can become expensive and require significant pre-planning. The applicability and accuracy of this technique are still the topic of considerable debates.

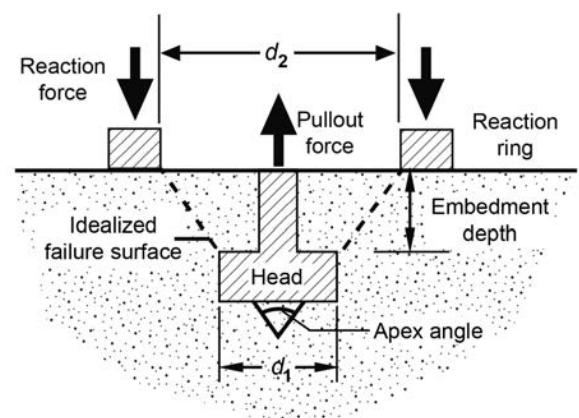

Figure 1-4: Pullout test^[3]

Concrete Maturity - From Theory to Application

1.5 Drilled Core (ASTM C42)

Drilling cores^[10] is a widely used technique to measure the in-place strength of the concrete when there are doubts regarding the existing construction or the results obtained from the field-cured specimens. It can provide a more accurate result than the field-cured specimens because it is subjected to the actual thermal history of the in-place concrete. However, it is a destructive technique that requires labor (Figure 1-5), time, and involvement of labs for compressive strength testing.



Figure 1-5: Drilled core test ^[25]

1.6 Cast in Place Cylinders (ASTM C873)

Cast in place cylinder^[17] is a relatively easy to use method which requires a mold, in which the sleeve is fixed to the formwork (Figure 1-6). During placement, the fresh concrete is poured as usual and the cylinder mold is filled and compacted. This technique is more representative of the real in-place strength of concrete compared to field-cured specimens because it is subjected to the same temperature and curing conditions as the structural element. However, the same limitations still arise. In particular, the cylinders need to be tested by the lab at different times until the concrete reaches the target strength. Also, this method is only applicable to 125 mm to 300 mm thick slabs. Once the cylinder has been removed, which can be difficult at times, the remaining hole in the slab must be patched.

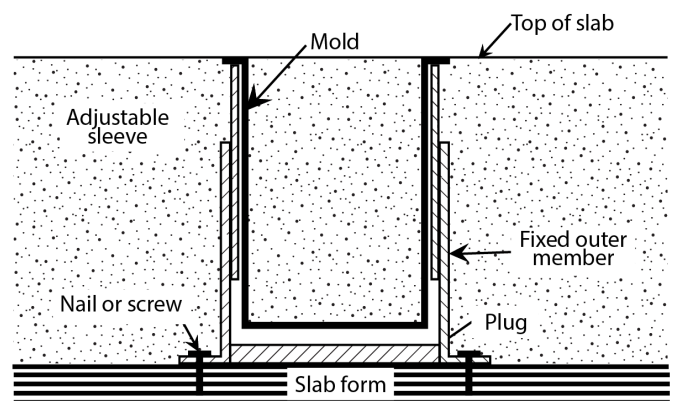
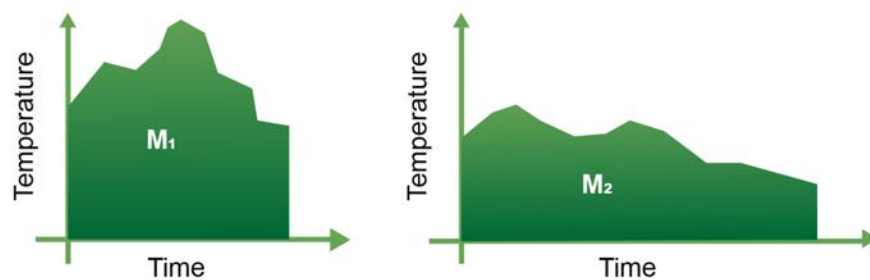

Figure 1-6: Cast in place cylinder test ^[3]

1.7 Maturity (ASTM C1074)

The concept of maturity^[20] is based on the temperature history of the concrete which can be used both as a quality control measurement of concrete temperature as well as in-place strength of concrete. The maturity concept can be illustrated in Figure 1-7. This chart shows how a specific concrete mix with a equivalent maturity index will have the same strength, independent of the time and temperature. As a non-destructive testing technique, the maturity method is a reasonable candidate to address most of the challenges that other in-place strength methods are facing. The privilege that this method has is that the procedure for estimating the compressive strength is impartial and quantitative once the maturity curve is developed and adopted. Furthermore, no delays would be expected as the strength measurement can be obtained directly on site. A step-by-step guide on how the maturity curve is developed and how it can be applied for on-site estimation of the early age strength of concrete is described in section 5 of this book.



$$\text{if } \text{Maturity}_1 = \text{Maturity}_2 \rightarrow f_{c_1}' = f_{c_2}'$$

Figure 1-7: Maturity concept

With the exception of the maturity method, all of the other methods have some limitations regarding the applicable range of compressive strength and/or location of the tests. Table 1-1 presents the accuracy, ease-of-use and required specifications for different in-place strength monitoring methods. Table 1-1 was adapted and modified from ACI 288.1R; since the last release of this ACI guide in 2003, As a result, new developments in technologies have made most of these methods easier to use, in particular the maturity method. Even though a large range of in-place techniques are available to contractors which measure the in-place strength, the preferred method is still, in most cases, the break tests. Lately, the maturity method has largely gained popularity in North America, as well as throughout the world, albeit at a slower pace. It is the preferred method for a wide variety of projects and applications. In this book, various aspects of the maturity method, its application, as well as its limitations, will be discussed in detail.

Concrete Maturity - From Theory to Application

Table 1-1: Summary of the accuracy and ease-of-use of in-place strength measurement techniques
(Adopted and modified from ACI 288.1R-03) ^[3]

Test Method	ASTM Standard	Accuracy *		Ease of Use *	Calibration Required
		New Construction	Existing Construction		
Rebound Hammer	C 805	+	+	++	Yes
Penetration Resistance	C 803	+	+	++	Yes
Pulse Velocity	C 597	++	++	+	Yes
Pullout	C 900	++	++	+	Yes
Drilled Cylinder	C 42	++	++	++*	No
Cast-in-place-Cylinder	C 873	++	N/A	+	No
Maturity	C 1074	++†	N/A	+	Yes

*++ represents more accuracy or ease-of-use compared to +.

** Based on the authors experience.

† Require verification (validation) by other tests.

— 2 Introduction to Maturity

The maturity method is a convenient approach to predict the early-age strength gain of concrete, using the principle that the concrete strength is directly related to the hydration temperature history of cementitious paste. The maturity concept for estimating the strength gain of concrete is described in ASTM C1074, *Standard Practice for Estimating Concrete Strength by the Maturity Method*.

ASTM C1074 - Maturity method definition: "a technique for estimating concrete strength that is based on the assumption that samples of a given concrete mixture attain equal strengths if they attain equal values of the maturity index^[20]."

This method can potentially address many immediate challenges facing the concrete industry such as predicting appropriate time for formwork stripping and post-tensioning, especially at low temperatures (while the strength development of concrete is hindered) and optimizing concrete mix design and concrete curing conditions (e.g. concrete heating at low temperatures or surface protection in hot-dry weathers). The lack of an accurate estimation of strength at early ages of construction has a two-fold impact: contractors either wait too long for their next action (e.g. stripping formwork), which is costly due to delays in completing the project, or they act prematurely. This can cause the concrete structure to crack, leading to future durability and performance issues or even structural collapse in some cases. A number of examples of failure due to early formwork removal have been reported, such as the collapse of the Skyline Tower in Fairfax County in 1973 (Figure 2-1) and a cooling Tower in Willow Island in 1978.

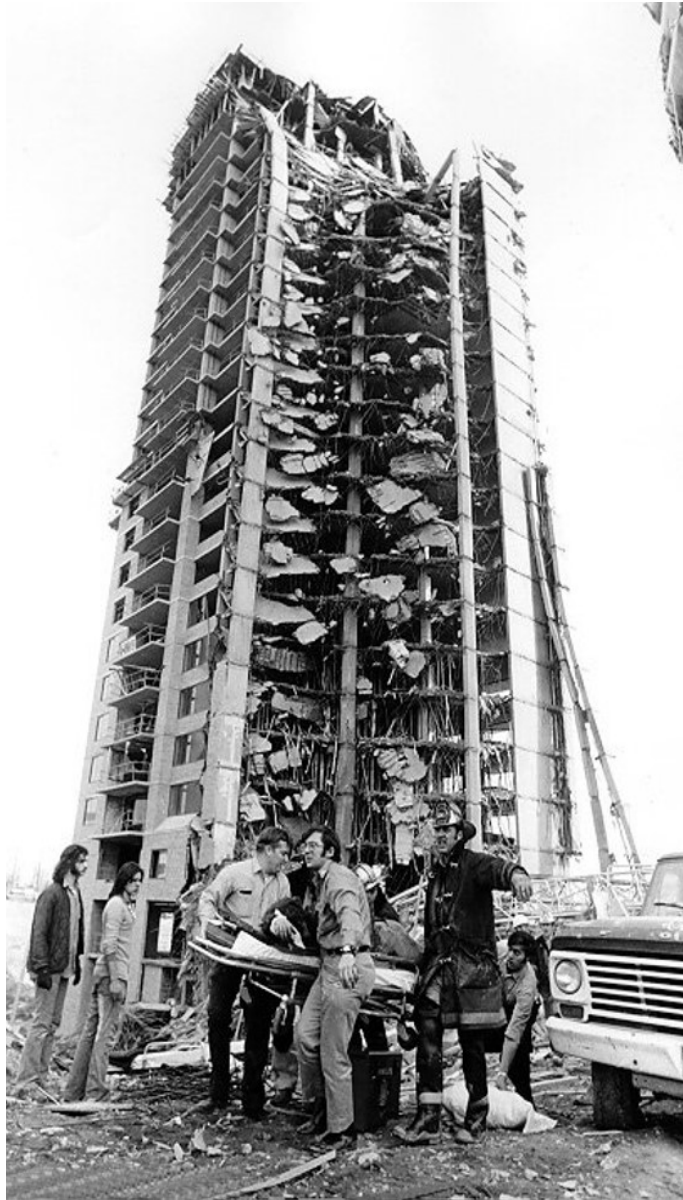

Figure 2-1: Collapse of the Skyline Tower in Fairfax County – 1973 ^[43]

Concrete Maturity - From Theory to Application

2.1 What is Concrete Maturity?

Maturity is a non-destructive method used to estimate the real-time strength development of the in-place concrete. It is based on the principle that concrete strength is directly related to its hydration temperature history. The maturity method is a relatively simple approach for estimating the in-place compressive strength of concrete, specifically at early ages less than 14 days.

This method is governed by the fundamental assumption that a given concrete mixture design poured during the course of a project has the same compressive strength at its "maturity index". For example, this means that a given concrete mix design may reach the same compressive strength after 7 days of curing at 10°C as when it is cured at 23°C for 3 days. This is illustrated schematically in Figure 1-7. When the concrete cures, it creates heat from cement hydration, which gets trapped inside the concrete element. The high temperature helps the concrete cure faster. The maturity method uses the variation of temperature within the concrete element to predict its strength. In comparison, field-cured cylinders have a much smaller mass and a larger surface area, which means the heat within the cylinder dissipates faster. As a result, this slows down the strength gain compared to the in-place concrete.

In most cases, the early-age strength of the concrete is underestimated when using the cylinder compression test. Contractors want to remove the formwork or post-tension as quickly as possible to move on to the next phase of the project. Since this method is more accurate in predicting the early-age strength, it allows for quicker removal and tensioning which saves time and money. A detailed comparison between the break test and maturity method is described in the next section.

The maturity method requires pre-calibration of a concrete mixture before it can be used to correlate the concrete maturity to its strength. Each maturity calibration is specific to a concrete mixture design. Once the maturity calibration curve is developed in the laboratory for a specific mixture, it can be used for on-site estimation of compressive strength of concrete in real-time. Figure 2-2 illustrates an example of a maturity-strength relationship. It is important to note that the development of computerized batching has made producers' standard deviations closer, increasing repeatability of the mixture which makes maturity even more reliable.

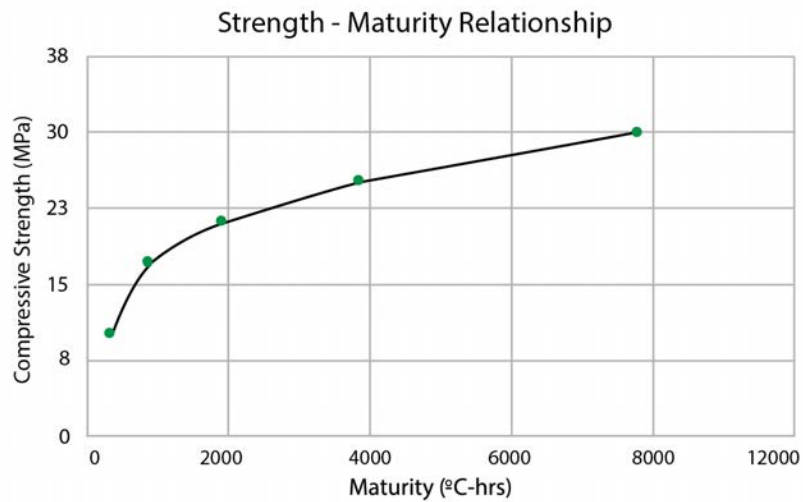

Figure 2-2: Example of a maturity-strength relationship

2.2 Cylinders vs. Maturity

The industry is predominantly using field cured cylinders to monitor the compressive strength of concrete. However, there are multiple advantages of using the maturity method with respect to test procedures, reliability, speed, and cost savings. Figure 2-3 summarizes the difference between these two test methods.

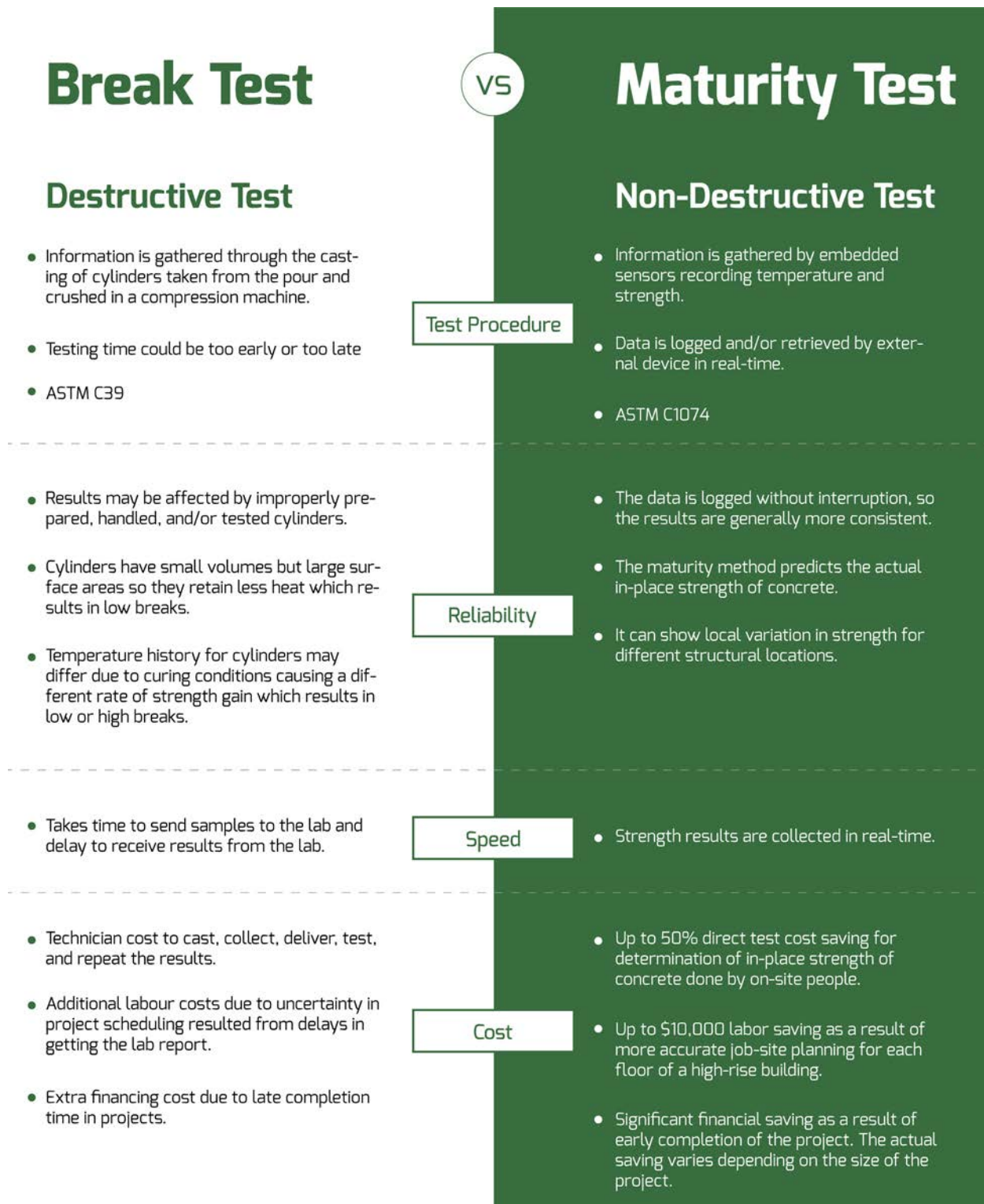

Figure 2-3: Break test vs. Maturity test

Concrete Maturity - From Theory to Application

2.3 Standards

The maturity method is widely standardized and accepted by building codes. This section summarizes different codes and standards accepted by different countries or regions. Countries that do not define maturity in their code typically follow ASTM standards. There are also multiple countries that are actively working on standardizing or approving the method for their own standard practice.

United States

ASTM C1074: Standard Practice for Estimating Concrete Strength by Maturity Method

ASTM C918: Standard Test Method for Measuring Early-Age Compressive Strength and Projecting Later-Age Strength^[19]

ACI 318- 6.2: Building Code Requirement for Structural Concrete and Commentary

ACI 228.1R: In-place Methods to Estimate Concrete Strength

ACI 306R: Guide to Cold Weather Concreting

AASHTO T325: Standard Method of Test for Estimating the Strength of Concrete in Transportation Construction by Maturity Tests.

DOT: The maturity method is widely adopted by most of the DOT's in the United States. As of January 2018, 29 states accept maturity as one of the testing methods in their specifications. A list of those states is presented in Table 2-1¹. The specifications in regards to maturity changes per DOT as some mandate the use of the maturity method, while others simply accept it as an alternative to field cured specimens or use it only for specific applications. Other states are currently in the process of implementing the method for future revisions.

¹ For additional information on DOT acceptance, consult the Use of the Maturity Method in Accelerated PCCP Construction, report from 2009 by Washington state Department of transportation (<https://www.wsdot.wa.gov/research/reports/fullreports/698.1.pdf>)

Concrete Maturity - From Theory to Application

Table 2-1: List of DOT's that accept the maturity method in their specifications

Alabama	Iowa	Montana	Rhode Island
Alaska	Kansas	Nebraska	South Dakota *
Arizona	Kentucky	New Mexico	Texas
California **	Louisiana *	New York	Utah
Colorado	Maine **	North Carolina	Virginia
Florida	Maryland	North Dakota	Washington
Georgia	Michigan	Ohio	West Virginia
Idaho	Minnesota	Oklahoma	Wisconsin
Illinois	Mississippi	Oregon	
Indiana	Missouri	Pennsylvania	

Note: Some DOT's accept the use of the maturity method but have not included it in their specifications.

* Maturity is accepted by the majority of USDOT's as a means to measure the in-place strength of concrete.

** Tests are being conducted by the DOT to evaluate the maturity method.

Canada

CSA A23.1/A23.2: Concrete Materials and Methods of Concrete Construction/Test Methods and Standard Practice for Concrete

South America

NCH 170: Hormigon- Requisitos generales (Concrete- General requirements)^[37]

Europe

Multiple European countries allow for the maturity method to be used as a measurement for in-place strength by specifying maturity in their own specific standards. The three standards that are generally used as a guide for measuring maturity:

EN 206-1: 2002, Concrete – Part 1: Specification, performance, production and conformity

BS EN 13670: Execution of concrete structures^[23]

NEN 5970: Determination of Strength of Fresh Concrete with the Method of Weighted Maturity^[38]

3 Monitoring System

Since the commercialization of the maturity method, there have been important advancements in monitoring and computing technologies such as: simple thermocouple, wireless sensors, manual data entry, cloud sharing systems, and more.

3.1 Wired System

The most primitive approach to measuring temperature is using a thermocouple. The end of the thermocouple is placed at a specific location prior to the pour and wired outside of the formwork. Depending on the type of system, thermocouples are attached to a data logger which is used to record the temperature at a certain time interval. An even more rudimentary approach can be taken in which there is no recording of a measurement. In this case, the data analysis is done manually to determine concrete strength, which is very labor intensive.

Concrete Maturity - From Theory to Application

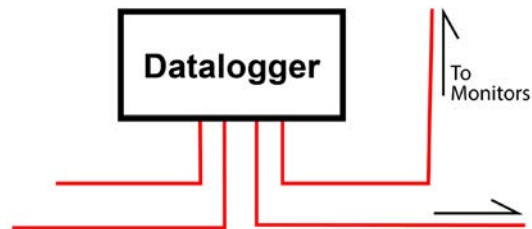
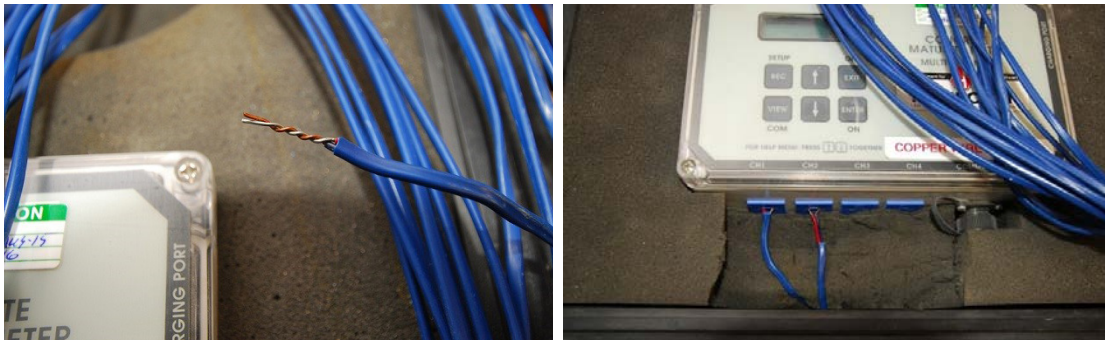

Figure 3-1: Simple datalogger and thermocouples monitoring

Upgrades to such systems have been developed focusing largely on the storage history of the temperature data within the sensors' internal memory (Figure 3-2). To retrieve the data, the worker connects the data logger to the sensor. This approach is widely used today and, with the help of technological improvements, it allows easier data gathering and sharing.

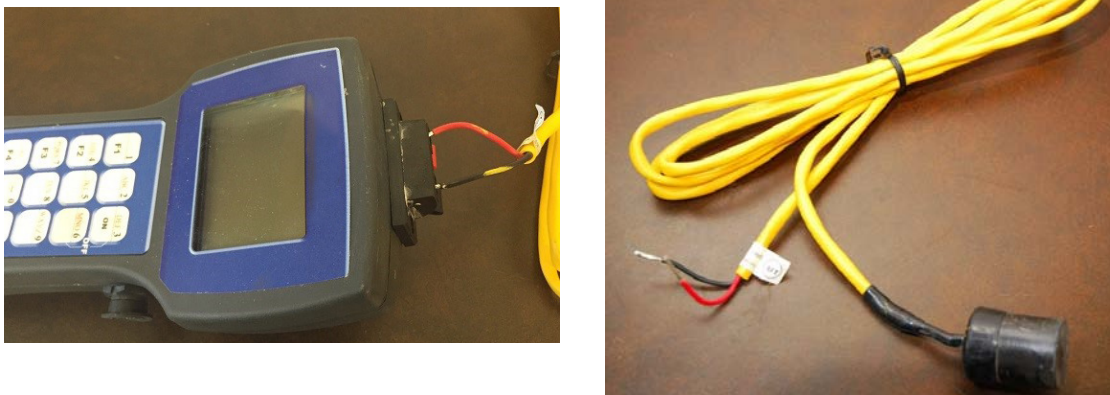

Figure 3-2: Wired system

Concrete Maturity - From Theory to Application

Another variant to the wired systems is a data logger/transmitter which sits outside the concrete in the form of a box connected to a number of temperature sensors. The transmitter uploads the data to the cloud server using wireless or cellular transmission technology.

The majority of commercial devices available for measuring temperature and maturity have long wires that need to be installed prior to the concrete pour and extended to a secure and accessible location. This can be a major drawback of the technique because of the unconventional work environment that is a construction site. Those cables can be easily damaged, during or after the pour, especially during the placement and finishing stages. Additionally, the data logger needs to be protected or kept in secure places for later access. Typical inconvenient cases are shown in Figure 3-3.

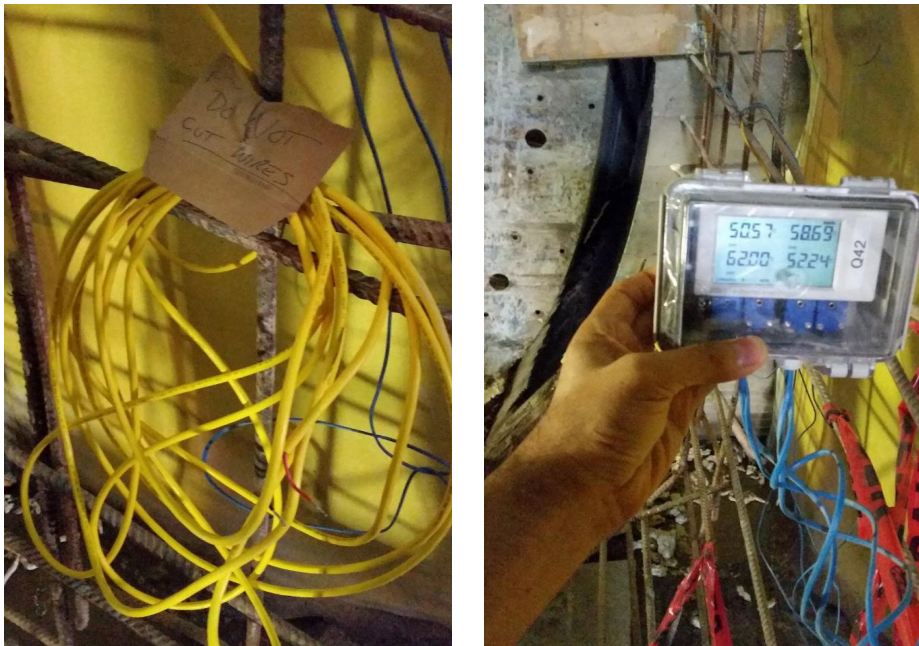

Figure 3-3: Drawbacks of wired systems

3.2 Wireless Technologies

Game-changing technology has also been developed and temperature/maturity monitoring systems can now be fully embedded in the concrete. Sensors/loggers (such as SmartRock) can be installed in the forms prior to the pour and temperature wires can be extended to the appropriate locations as shown in Figure 3-4. Once concrete is poured, the sensors are completely covered and no system components are exposed out of the concrete. The data is collected using wireless communication through a smartphone application. The application

Concrete Maturity - From Theory to Application

performs automatic maturity and strength calculation (as long as a calibration curve is provided) and the information can be conveniently shared to team members for easy collaboration and data viewing.

The main limitation in this approach is the maximum allowable distance between the sensor and the surface of the concrete. Concrete can block wireless signals and loggers usually need to be placed within a certain distance from the surface to ensure connectivity. To address this issue, sensors come in different lengths to accommodate different situations.



a) Before pouring



b) After pouring

Figure 3-4: Wireless maturity sensors

4 Calculation Methods

Maturity is a concept that has existed since the 1950s. Since then, various equations have been proposed to calculate the maturity of concrete. This chapter discusses three different methods that can be used to calculate maturity: the temperature-time factor, the equivalent age, and the weighted maturity. All of the maturity methods are primarily dependent on the temperature history of the concrete but additional parameters related to concrete properties are also required to predict the in-place strength.

4.1 Temperature-Time Factor

The temperature-time factor (TTF) method, also known as the Nurse-Saul maturity function, was the first maturity method developed in the early 1950s, thanks to the work of Nurse^[40], McIntosh^[36] and Saul^[42]. The goal of their work was to understand the effect of accelerated curing and the impact of different curing temperatures on the strength development of concrete. This method was standardized in 1987 by ASTM C1074. Today, the Nurse-Saul function is the most commonly used maturity method in North America because of its simplicity.

This approach takes into consideration that maturity is linearly dependent on temperature and can simply be represented by the area below the temperature curve, as graphically shown in Figure 4-1. In this approach, the area under the temperature curve is taken as the difference between the average recorded temperature and the datum temperature (T_d). The datum temperature is defined as the temperature at which the hydration of the cement stops, in other words, the temperature at which concrete stops developing strength. The Nurse-Saul equation is mathematically represented as follow:

Concrete Maturity - From Theory to Application

$$M(t) = \sum (T_a - T_d) \Delta t$$

(Eq. 4-1)

$M(t)$ Maturity at Age t (°C-hrs)

T_a Average Temperature (°C)

T_d Datum Temperature (°C)

Δt Time Interval (hrs)

Notes: Days can also be used as the units for the time interval

1°C-hrs = 1.8 °F-hrs

Most of the variables in Eq. 4-1 can easily be obtained without a complex analysis. T_a is simply obtained by the maturity monitoring system at a given time. Δt is the default value given by the frequency of measurements taken by the maturity meter and is usually defined as 1 hour, 30 min, or less. The only variable that is unknown and needs to be calculated or estimated is the datum temperature. For a better accuracy, T_d can be calculated through laboratory testing as specified in ASTM C1074, but, in most cases, it can be defined as 0°C (32°F), -5°C (23°F) or -10°C (14°F).

ASTM C1074 states that: "for type I cement without admixture and a curing range between 0 to 40°C, the recommended datum temperature is 0°C". Originally, the datum temperature was defined as -10°C [22] [30]. However, studies have shown that the datum temperature for any given type of cement is within 0 to -10°C [24]. Assuming a 0°C datum temperature in most cases is often considered a conservative approach, as it assumes that there is no strength gain if the temperature of the concrete falls below freezing point. Since concrete cannot lose strength as it hydrates, any given condition that would cause $(T_a - T_d) \leq 0$ would result in no strength gain, $M(t) = 0$.

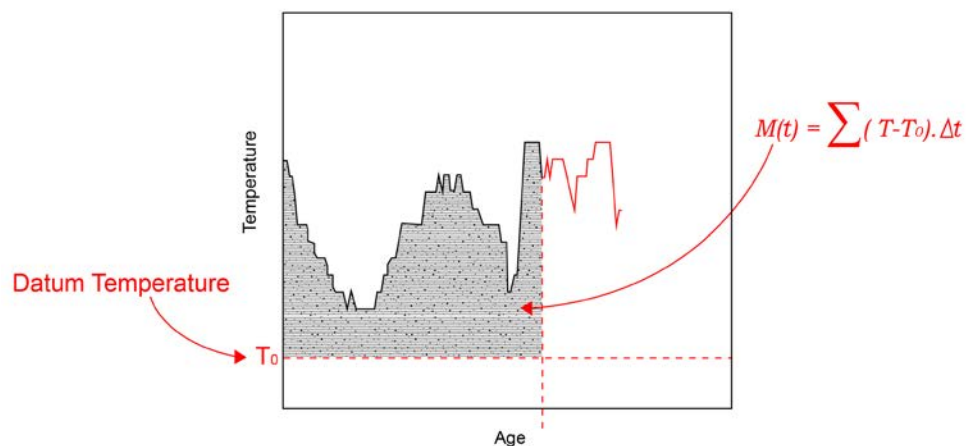

Figure 4-1: Temperature-Time Factor method

Concrete Maturity - From Theory to Application

During the summer, when the temperature of the concrete is higher, assuming any datum temperature from 0 to -10°C for calibration will not necessarily have a significant impact on the results. However, in winter when the temperature can easily fall below freezing in certain regions, closer attention needs to be given when determining the actual datum temperature. In general, project specifications require that the temperature of the concrete remain above a certain temperature (>5°C [5] [26]) for a certain period of time during curing.

Example

Figure 4-2 and Figure 4-3 below show an example of maturity and strength calculations using different datum temperature (0°C, -5°C, -10°C). Each maturity calibration curve was developed by taking into account the different datum temperature to calculate maturity for the same strength data. The difference of those three mix calibrations are shown in Figure 4-2, where it is possible to observe that any difference is simply a shift to the right because the maturity corresponding to each strength gets larger as the datum temperature decreases (more area under the temperature curve). Given a temperature curve that falls below freezing point, it is possible to observe how the maturity and strength value can vary for different datum temperatures (Figure 4-3).

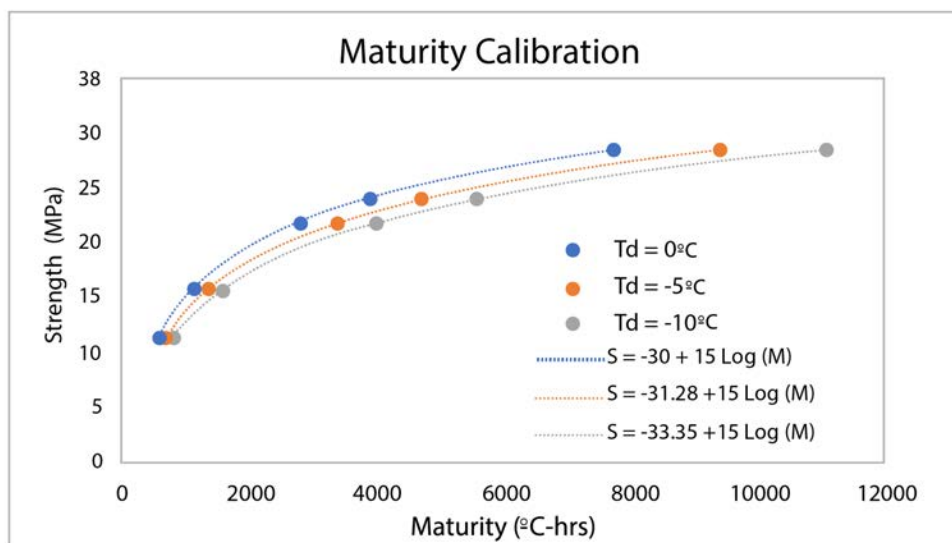
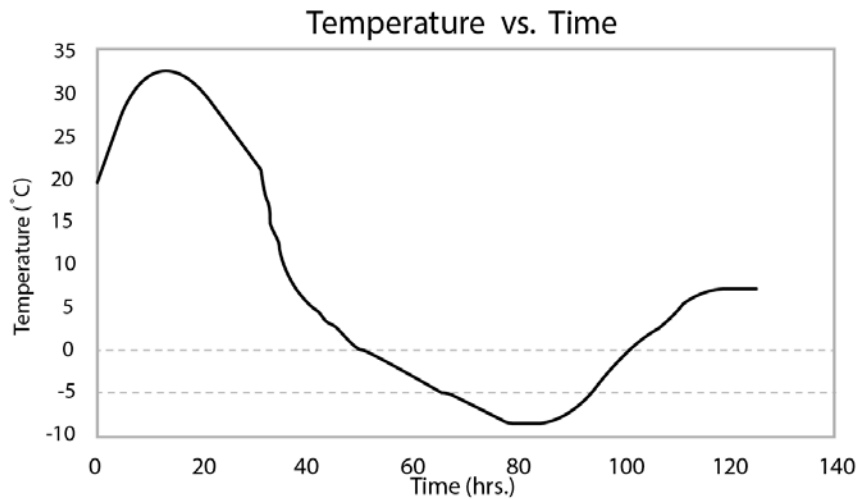
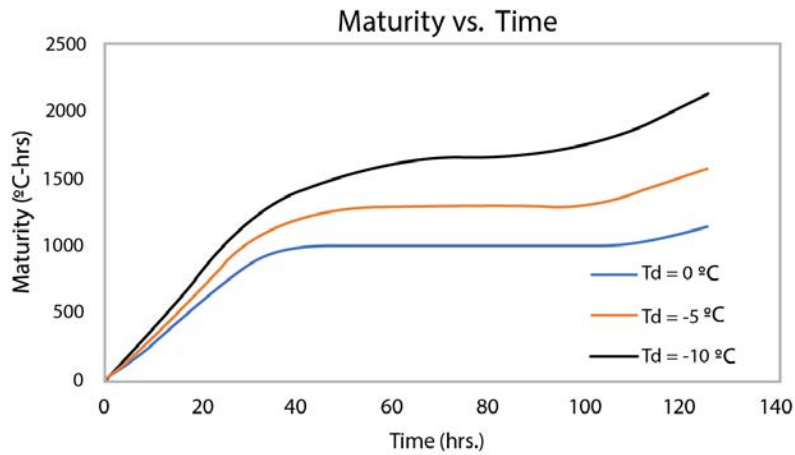

Figure 4-2: Mix calibration (example)

Concrete Maturity - From Theory to Application



a) Example- Temperature profile



b) Example- Maturity calculation (TTF)

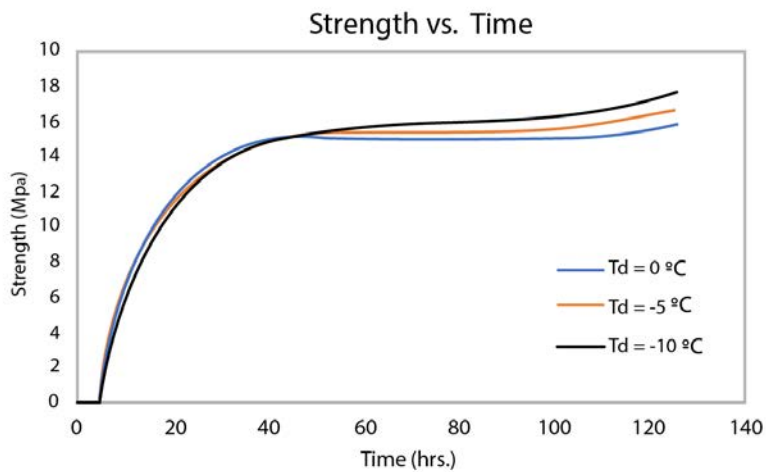

c) Example- Strength calculation

Figure 4-3: Effect of datum temperature on the maturity and strength calculations (example)

Concrete Maturity - From Theory to Application

4.1.1. Datum Temperature Calculation

As mentioned above, T_d can be defined as 0°C for simplicity (other temperatures also used in the industry are -5°C and -10°C). Nevertheless, it is possible to determine the datum temperature by following the steps provided in ASTM C1074 A1, which are summarized below.

The datum temperature procedure consists of making a minimum of 54 mortar cubes (ASTM C109⁽¹¹⁾) representing the concrete mix. The cubes should be divided into 3 different sets; each containing 18 cubes. Each of these three sets will be cured at a different temperature. The temperature chosen for curing should be based on the maximum and minimum expected curing temperature as well as an average temperature of the jobsite. Three cubes are then broken at six different times to obtain the strength of the concrete (ASTM C109⁽¹¹⁾).

4.1.1.1. Rate Constant (K-value)

To calculate the datum temperature, the k-value must be determined for each curing condition. The k-value is the reaction rate constant which is dependent on time and temperature. It represents the rate of the chemical reaction, in this case, the cement hydration reaction which represents the strength development in concrete.

There were originally 3 approaches suggested by ASTM C1074 to determine the k-value, in the last revision of ASTM C1074 only one approach was kept as the standard procedure to determine the reaction rate k.

The k-values can be solved using a computer program for Eq. 4-2⁽²⁴⁾. In this equation, in addition to the rate constant, t_o and S_u are also unknowns that need to be solved, ASTM C1074-17 provides an example of calculation and spreadsheet set up to solve for those parameters.

$$S = S_u \frac{k(t - t_o)}{1 + k(t - t_o)} \quad (\text{Eq. 4-2})$$

Where:

S Average compressive strength of the test cube at time t

t Test age

S_u Limiting strength

t_o Age when strength development is assumed to begin

k Rate constant

Concrete Maturity - From Theory to Application

Once the k-value has been calculated for each curing temperature, the reciprocal of k vs. curing temperature can be plotted. By fitting a linear interpolation, the intersection with the x-axis represents the datum temperature (Figure 4-4).

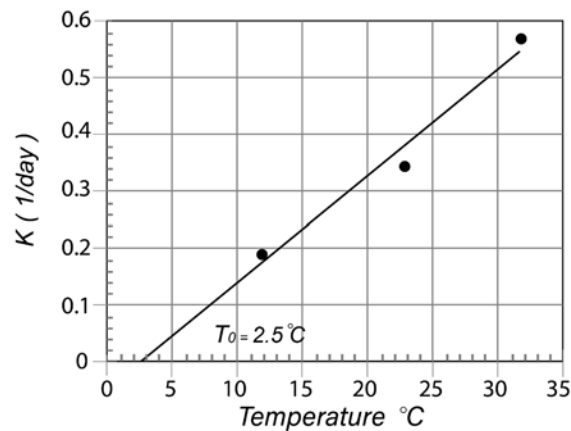

Figure 4-4: Datum temperature

4.2. Equivalent Age

Even though the temperature-time factor equation is widely used and accepted worldwide, the linear approach to determine maturity is not accurate for all curing conditions, especially at temperatures outside the range of 0-40°C. To mitigate this effect, in 1977 Freiesleben-Hansen and Pedersen^[32] proposed a more accurate equation in which the maturity is exponentially dependent on temperature. This maturity method is known as the equivalent age method and is based on the Arrhenius equation. This approach is standardized in most codes including ASTM C1074 and European standards (European countries typically allow the Arrhenius method instead of the Nurse-Saul). Despite the fact that this approach is a bit more complex than the temperature-time factor, if the assumptions are done properly, it can lead to a more accurate prediction of the in-place strength. The equivalent age can be calculated using Eq. 4-3.

$$t_e = \sum e^{-Q\left(\frac{1}{T_a} - \frac{1}{T_s}\right)\Delta t} \quad (\text{Eq. 4-3})$$

Where:

- t_e Equivalent age at T_s (hrs. or days)
- T_a Average temperature during Δt (Kelvin)
- T_s Specified temperature (Kelvin)
- Q Activation energy divided by gas constant (Kelvin)
- Δt Time interval (hrs. or days)

Similar to the Nurse-Saul equation, T_s and Δt can be obtained from the maturity meter. T_s represents a specified temperature and is usually defined as 23°C in North America and 20°C in Europe. The activation energy divided by gas constant must be determined experimentally using very similar steps as shown in the calculation of datum temperature. ASTM C1074 also proposes a standard value where Q can be defined as 5000 K for type I cement without admixtures.

To determine Q , the k -value must be obtained following the same steps presented in Section 4.1.1.1. By plotting the natural logarithm of k vs. the reciprocal of the curing temperature (in Kelvin), the negative of the linear slope represents Q .

4.3 Weighted Maturity

The third method proposed to calculate maturity is the weighted maturity, which was developed in the 1970s by Papadakis and Bresson and later modified by de Vree in 1979. This method is not typically used in North America as it is not standardized by ASTM C1074. However, it is currently standardized in the Netherlands (NEN5790) and accepted in Europe.

The general approach of the weighted maturity method is described in Eq. 4-4. This equation is very similar to the Nurse-Saul equation as $t_k T_k$ represents the area under the temperature curve while the C^{n_k} represents a correction factor.

Concrete Maturity - From Theory to Application

$$M_w = \sum t_k - T_k C^{n_k} \quad (\text{Eq. 4-4})$$

Where

- M_w Weighted Maturity (°C-hrs)
- t_k Hardening Time of Concrete (hrs)
- T_k Hardening Temperature Interval
- C C-value of Cement
- n_k Temperature-Dependent Parameter for T_k

Using this equation is, however, not practical as the n_k factor is temperature-dependent. A discontinuous function to simplify the calculation of the proposed linear equation (Eq. 4-5), can be used in determining the n parameter. Therefore, the weighted maturity equation can be rewritten in a simpler form by taking the integral of C^{n_k} from datum temperature (-10°C) to average temperature. The weighted maturity equation can now be defined as Eq. 4-6 with a continuous n function. It is graphically represented in Figure 4-5.

$$n = 0.1T - 1.245 \quad (\text{Eq. 4-5})$$

$$M_w = \sum_0^t \frac{10(C^{0.1T-1.245} - C^{-1.245})}{\ln C} \Delta t \quad (\text{Eq. 4-6})$$

Where

- M_w Weighted maturity (°C-hrs)
- T Average temperature during the time interval
- C C-value of cement
- Δt Time interval (hrs)

Concrete Maturity - From Theory to Application

The C-value is a cement-specific value which indicates the influence of the sensitivity of the cement to temperature. The C-value can be obtained directly from the cement producer or through the standardized procedure in NEN 5790. The value typically varies from 1.25 to 1.75.

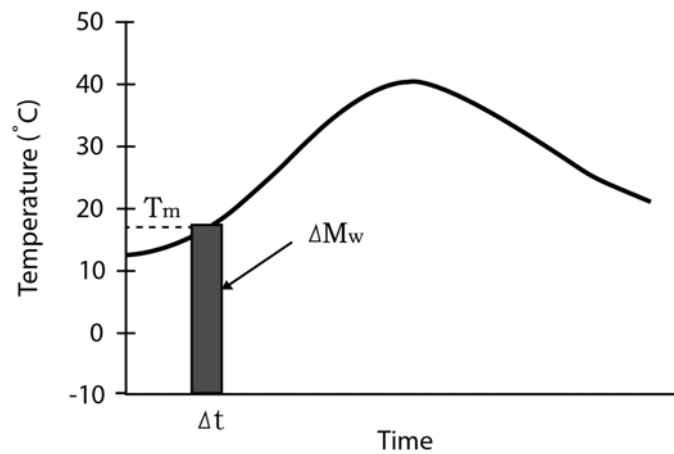

Figure 4-5: Weighted maturity ^[30]

5 Calibration

In order to use maturity to determine the in-place strength of concrete, calibration (strength-maturity relationship) is required. Each calibration is unique for a specific mix and its properties. The goal of the calibration is to associate the strength to a maturity index at specific times. The maturity-strength relationship is developed in the lab and can later be used to determine the in-place strength of the concrete on site. Independent of the maturity method used, the logarithm of maturity index can be linearly correlated to the strength of the concrete. The following logarithm equation (Eq. 5-1) can be used to represent the maturity-strength relationship, where a and b are constants. An example of maturity-strength calibration is shown in Figure 5-1.

$$\text{Strength} = a + b \text{ LOG}_{10}(\text{Maturity}) \quad (\text{Eq. 5-1})$$

Table 5-1: Example of strength-maturity relationship data

Maturity (°C-hrs)	Strength (MPa)
500	10
1500	20
3000	25
7000	30
15000	35

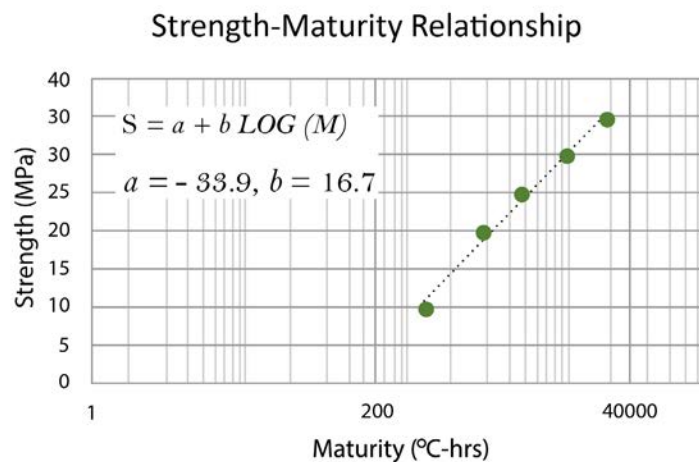

Figure 5-1: Example of strength-maturity relationship equation

The logarithm equation presented above is the most commonly used equation and well-established relationship between strength and maturity. In some cases, especially for calibration at a very early age, this correlation might not be practical. A note in the ASTM C1074 standard mentions that: "The strength-maturity relationship can also be established by using regression analysis to determine the best-fit equation to the data". If a different fitted curve from the one proposed in Eq. 5-1 is used, it cannot be considered a general equation and would only be valid for a specific mixture and for a certain range of maturity and strength.

Concrete Maturity - From Theory to Application

5.1. Calibration Test Procedure

To perform a calibration, the same sample size must be tested for both strength and temperature. This can be achieved in the lab by testing multiple cylinders. A maturity calibration cannot be done by measuring the temperature of on site elements such as a slab or other structural elements because maturity is almost solely based on temperature. The temperature in structural elements is completely different compared to the temperature of the cylinders that are tested for compressive strength. In other words, when doing a maturity calibration, it is required to compare the temperature of a cylinder to the strength of a cylinder (comparing apples to apples).²

All the necessary information related to the development of the maturity-strength relationship is described in Section 8 of ASTM C1074, and in other equivalent standards. Before starting a maturity calibration, the standard must be reviewed in detail. All of the information below is a summary of the standard and provides additional information and tips to successfully complete a calibration procedure.

5.1.1. Number of Data Points

The first step in the calibration procedure is to determine how many points need to be included in the calibration curve and at what ages the cylinders must be tested. The ASTM C1074 standard requires a minimum of 5 points and gives the default testing time to be 1, 3, 7, 14, and 28 days. However, it is the engineers' decision to change the age of testing in order to optimize the calibration of concrete for specific applications, as long as there are at least 5 data points on the curve.

Tip #1: In most cases, the maturity method is used for stripping formwork or tensioning as early as possible. The 28-day strength might not be required as the targeted strength will most likely be achieved within the first 7 days after the pour. More data points towards the early age of the concrete can be selected. For example, the following ages can be used: 1, 2, 3, 7, and 14 days. This will reduce the time required to complete calibration and increase the precision of the curve for early age strength. However, a larger error may be expected for the 28-day strength default testing time.

Tip #2: For time-sensitive operations, such as opening a road or bridge as quickly as possible, it would be appropriate to use very early-age calibration data points (e.g. 3, 6, 12, 24, 36, or 48 hrs) for high early-strength concrete. This will greatly increase the precision of the calibration at an early age. In this case, the ASTM recommendation of 1 day for the first point of the calibration curve might not be appropriate.

² Cylinders are being referred to as the default type of sample for calibration, but in all cases cubes or beams (for flexural strength) can also be used

Concrete Maturity - From Theory to Application

Tip #3: When selecting the testing ages, try to select as many points as possible before the targeted time, such as one point at your target time and at least one point after the target time. This should give you a good calibration quality overall. Five data points is the minimum requirement but more points can be used for the calibration. Keep in mind that the maturity method was typically developed for the first 14 days and is not meant to estimate strength at 28 or 56 days as that would provide a larger margin of error.

5.1.2. Calibration Cylinders

The code states that a minimum of 17 cylinders are required for calibration. Two of those cylinders must be used for temperature monitoring while the others must be used for compressive strength. For each of the testing times selected, three cylinders must be made.

One temperature-monitoring instrument must be placed in each of the two cylinders dedicated to temperature monitoring. This will allow for the determination of an average of the maturity index. The temperature probe must be placed at the center of the cylinder. The temperature interval must be 30 min or shorter for the first 2 days of recording. Longer time intervals (e.g. 1 hr) can be used when the concrete has reached equilibrium with the curing temperature. The remaining cylinders will be used for strength monitoring. At each curing age, a minimum of two cylinders must be tested. If the strength values vary by more than 10% from the average, a third cylinder must be tested.

Tip#1: Try to use concrete directly from the truck to cast the cylinders. This will take into consideration some source of errors and would be more representative of the real concrete received on site compared to concrete batched in a lab. In this case, make sure the concrete cylinders are cured according to ASTM C31^[8].

Tip#2: Clearly identify the cylinders with the temperature sensors; those should not be tested for strength.

Tip #3: When breaking a cylinder, clearly note the time and date of the break.

Tip #4: Even if strength data within 10% of the average is obtained by breaking two cylinders, the third cylinder is already made. Break the third cylinder to obtain a better average or use the remaining cylinders to generate more points for the calibration curve.

Concrete Maturity - From Theory to Application

5.1.3. Curing

Once the cylinders are casted, they must all be placed together under specific curing conditions. This will ensure that temperature and curing conditions are the same in the concrete cylinders that are being tested for strength and the ones being used for maturity calculation. The ASTM C1074 standard specifies that the samples must be cured in a water bath or a moist room (ASTM C511^[13]).

Tip#1: One may find that the calibration done in a moist environment is not representative of the field environment (especially in warm countries). In those cases, a more simplistic approach, such as using wet burlap and plastic covering during curing, can be used. If this approach is taken, validation of the curve is extremely important since it is not a standardized approach.

Tip #2: If the cylinders used for calibration are casted on site, make sure to cure them appropriately (ASTM C31^[8]) before they are transferred to the testing lab.

5.1.4. Building the Maturity-Strength Relationship

For each of the ages selected, the strength is obtained by breaking the cylinders (ASTM C39^[9]). At the same time, maturity is also calculated, using any of the equations presented in Chapter 4, based on the temperature data recorded from the concrete cylinder. For each specified time, strength and maturity can be correlated. This process is depicted in Figure 5-2 to Figure 5-4.

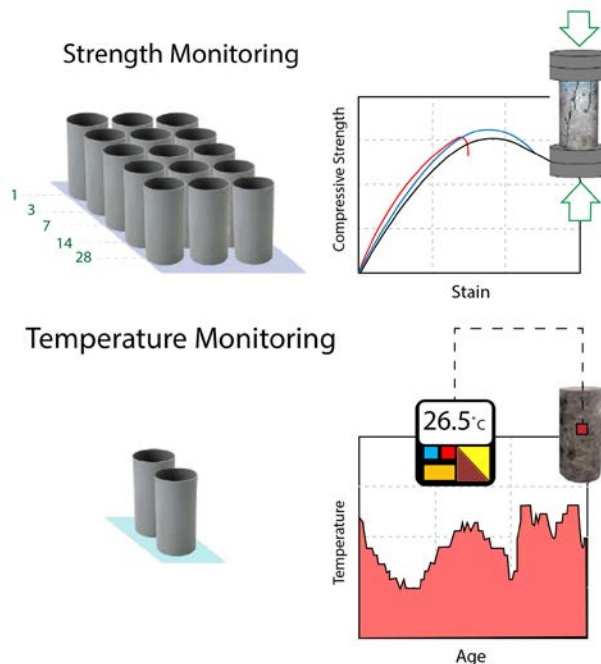

Figure 5-2: Calibration cylinders

Concrete Maturity - From Theory to Application

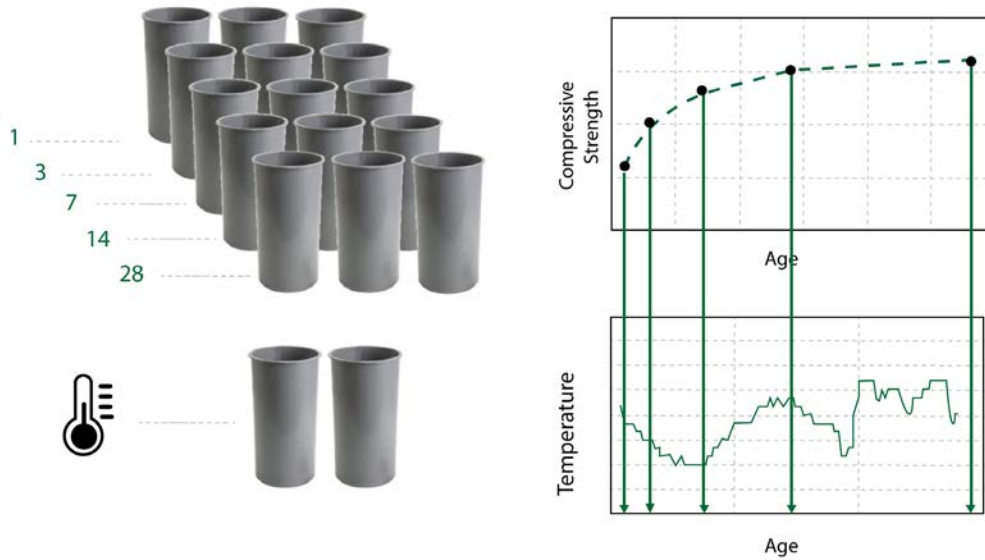

Figure 5-3: Correlating strength to maturity data

Develop Maturity Curves

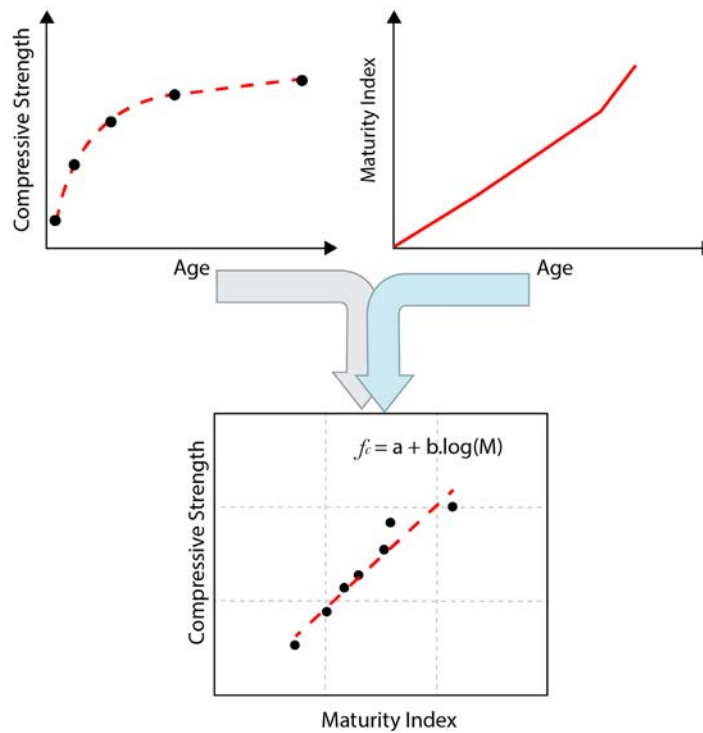

Figure 5-4: Combining strength and maturity to obtain a calibration

Concrete Maturity - From Theory to Application

The a and b values from Eq. 5-1 can easily be calculated using Microsoft Excel's curve fitting logarithm. Note that Excel will only provide the fitted curve using the natural log. Make sure the equation from the fitted curve is converted to the base 10 logarithm. Alternately, an online calculator³ is also available to calculate maturity and a and b values.

5.2. Example

Let's assume a constant concrete temperature of 20°C. The Nurse-Saul equation is used to calculate the maturity with a datum temperature of 0°C.

- Calculate the maturity index at day 1, 3, 7, 14, and 28.
- Using the following break test (Table 5-2) results, determine the equation of the strength-maturity relationship.
- If the maturity of the concrete reaches 2500 °C-hrs, what is the estimated in-place strength?

Table 5-3: Example- Maturity-Strength Data

Day	Maturity (°C -hrs)	Strength (MPa)
1	480	10
3	1,440	20
7	3,360	25
14	6,720	30
28	13,440	35

Solution:

(a)

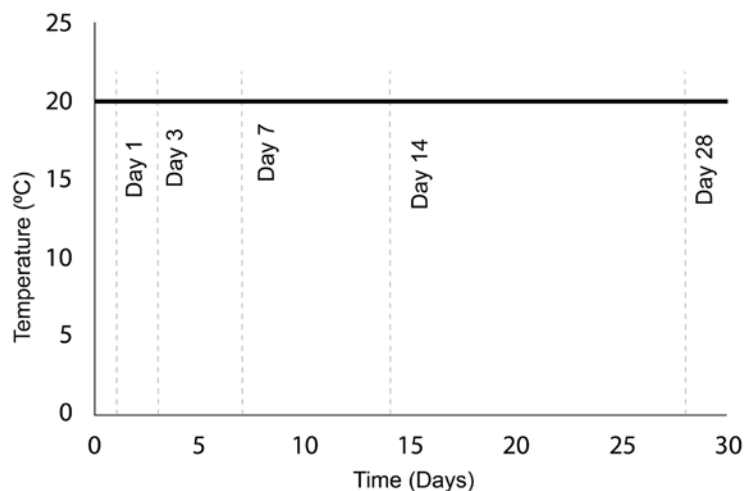

³ <https://www.giatecscientific.com/products/concrete-sensors/smartrock-maturity-meter/resources/concrete-maturity-tool/>

Concrete Maturity - From Theory to Application

Using Eq. 4-1: Since the temperature is constant, the average temperature at any given point is $T_a = 20^\circ\text{C}$, T_d is set to 0°C .

$$M(t) = \sum(T_a - T_d) \Delta t$$

$$M(\text{Day1}) = (20^\circ\text{C} - 0^\circ\text{C}) * (24\text{hrs})$$

$$M(\text{Day1}) = 480^\circ\text{C} - \text{hrs}$$

Repeating for subsequent days:

Table 5-3: Example- Maturity-Strength Data

Day	Maturity ($^\circ\text{C} - \text{hrs}$)	Strength (MPa)
1	480	10
3	1,440	20
7	3,360	25
14	6,720	30
28	13,440	35

(b) Using the data in the table above, a maturity-strength relationship can be created. The a and b values can be determined by fitting the curve. In this case, $a = 34.66$ and $b = 16.93$.

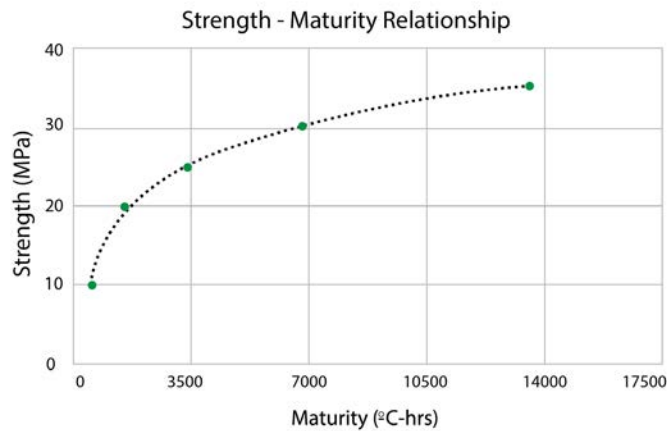

Figure 5-6: Example-Maturity-strength relationship

(c) For maturity of $2,500^\circ\text{C-hrs}$.

$$S = -34.66 + 16.93\text{LOG}(2500)$$

$$S = 22.8\text{MPa}$$

Concrete Maturity - From Theory to Application

5.3. Validation

Once the in-place strength has reached the desired levels, ASTM C1074 Section 9 requires that additional testing be done before proceeding with critical applications. The reason behind this process is to validate if the in-place concrete is similar to the one used for the calibration. In other words, this test is done to verify that the concrete placed followed the specification of the delivered concrete. There are four proposed ways to determine this:

1. Cylinders subjected to accelerated curing (ASMT C684^[19]) can be tested for comparative compressive strength.
2. Verification of compressive strength can be done by testing a standard-cured cylinder according to ASTM C918.
3. Verify the in-place strength by using other in-place methods such as ASTM C873^[17], C803 or C900. This however, is not very practical as some of those methods require calibration or have some limitations.
4. The fourth approach consists of placing a maturity meter in a cylinder that is being field cured (ASTM C31^[8]). Field-cured cylinders are broken and the strength can be compared to that obtained from maturity. If more than 10% error is observed, the calibration curve must be calculated again. Usually, the validation is accurate within a 5% margin if the calibration cure is done properly with a consistent mix.

5.4. Simplified Approach

A simplified approach can be used to estimate a calibration curve. This approach is **not standardized and cannot be used for any critical operations** such as post tensioning or formwork stripping. The simplified approach can, however, be used to optimize break tests until the maturity calibration has been completed.

The simplified approach can be done by having the break test information from the ready-mix producer. This approach takes into consideration that the cylinders were cured under constant temperature in a curing room or tub and that the temperature of the cylinder was the same as the curing condition at any given time. In reality, as the cement hydrates, it creates heat which increases the temperature of the cylinder for a short period of time since they are small. The simplified method ignores this increase in temperature as it assumes a constant concrete temperature. This approach will most likely give a higher difference than the 10% error acceptance specified in ASTM C1074, which is why it can only be used to optimize the break tests. The example shown in Section 5.2 represents the simplified approach.

5.5. Limitations

The maturity method is arguably one of the most accurate techniques to determine the in-place strength of concrete. However, this technique takes into account some assumptions, resulting in limitations.

1. The in-place concrete mixture is assumed to be exactly the same as the one used for calibration. The maturity method cannot detect any changes in materials, w/cm, air content, etc., because those properties only affect the strength of the concrete and not its temperature. As previously mentioned, the development of computerized batching has made producers' concrete more consistent which makes the maturity method more reliable. To mitigate this limitation, some suggestions are presented in the next section.
2. The maturity method takes into consideration that the in-place concrete has had enough moisture to allow cement hydration. The placement, consolidation, and curing of concrete must follow the standard specifications.
3. High temperatures at early ages can affect the long-term strength of concrete. Additional tests, such as ASTM C918^[49], can be performed for better predictions of later-age strength.
4. If they are not experimentally calculated, a good estimate for datum temperature and activation energy must be made to obtain acceptable accuracy.
5. The calibration must be kept up-to-date and verified on a regular basis, especially when the source or quality of raw materials in the mixture changes.
6. The goal of this method is to replace the field-cured specimens at early ages (less than 14 days). The standard lab-cured specimen approval for 28 day strength is still required for quality control of concrete.
7. For critical operations, additional tests must be performed as described in Section 5.3.

5.6 Frequently Asked Questions

As the maturity method increases in popularity worldwide, more standards are adopting this method. As a result, more questions are being asked about how maturity can be used for different applications and its limitations can be addressed. This section focuses on answering the questions typically asked by engineers, ready-mix producers, contractors, and testing labs regarding the maturity method and its applications.

- **Is the calibration still valid if there is additional water or air added to the mix?**

A calibration is specific to one mixture design with specific properties. Any additional changes in materials or mixture properties would affect the strength (or rate of hydration), which would make the calibration invalid. For any change in the mixture, a new calibration should be created.

Unfortunately, it is unrealistic to assume that the exact same mixture used for calibration is used in an actual construction jobsite. It is normal that some additional water or variation in air content occurs in the mixture. For this reason, it is recommended to use concrete that is delivered to the jobsite for the calibration curve which minimizes some of these potential sources of error. Another approach would be to build the calibration curve with a mixture that still meets the specifications but with slightly higher w/cm and air content. This will, subsequently, incorporate some safety margins to the calibration.

- **Is the calibration still valid if retarders or accelerators are added to the mix?**

The goal of the retarder is to delay the setting time. This will affect the rate of strength development by shifting the hydration to a later time. On the other hand, the goal of accelerators is to expedite the setting time and strength gain at an early age. There exists multiple types of chemical admixtures, some with or without water, reducing specifications ^[12]

. Retarders and accelerators can affect the compressive and flexural strength properties of the concrete specifically at an early age. For this reason, it is important that the maturity calibration be done with the accelerator or retarder incorporated into the mix. If the dosage of the chemical admixture varies from the one used during maturity calibration, a validation of this measurement is necessary and recalibration could be required. Depending on the admixtures, it's possible that a different dosage of the admixture has only minimal effect on maturity calibration.

- **Should safety factors be added to the mix calibration?**

ASTM C1074 doesn't specify that safety factors need to be implemented during maturity calibration. Some suggestions have been proposed in this document to mitigate the need for incorporating safety factors. However, at the discretion of the engineers, a safety factor can

Concrete Maturity - From Theory to Application

be applied to the maturity calibration curve. The first approach would consist of applying a safety factor to the obtain strength data during calibration. A second approach is proposed by the RILEM Committee TC's ATC report ^[31] on the maturity method which suggests a small modification to Eq. 5-1 by including a vertical shift (δ) in the calibration curve, resulting in a lower strength output for a given maturity (Eq. 5-2). This approach is shown in Figure 5-7 and the correction factor can be calculated through Eq. 5-3 and Eq. 5-4.

$$S = a + b \text{LOG}_{10}(M) - \delta \quad (\text{Eq. 5-2})$$

$$\delta = s * \sigma \quad (\text{Eq. 5-3})$$

$$\sigma = f_c * C_v \quad (\text{Eq. 5-4})$$

S is a parameter that provides safety margins based on the application of the maturity method in the project and is defined as 0 for determining the period of curing, as 1 for stripping formwork, and 1.5 for post and prestressing. σ represents the standard deviation of the calibration, where f_c is the mean measured strength in the calibration, and C_v is the coefficient of variation.

Another way to incorporate a safety factor is to ensure that critical operation is done only when all maturity readers have reached the required maturity/strength. The last portion of the structure that is casted will typically represent a lower strength.

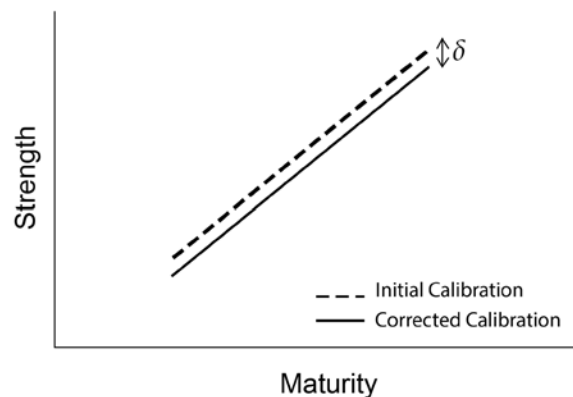

Figure 5-7: Maturity calibration including safety factor

- **How long is the calibration valid for?**

Technically, the calibration is valid until an element from the mix is changed. In general, validation should be done periodically, or before/during critical operations. During validation,

Concrete Maturity - From Theory to Application

if the differences consistently exceed 10%, a new maturity calibration needs to be developed. This is particularly essential for the general contractors who are doing the mix calibration as they do not have full control over the mixes. However, ready-mix producers who are performing maturity calibrations have better knowledge and control of their mixes.

- **What should be expected when comparing the results from field-cured specimens and in-place strength calculated by maturity?**

One should expect a difference between the results of the cylinders and the in-place concrete. In general, the maturity method would produce higher strength results because of the larger size of the structural elements compared to concrete cylinders, which makes the process of heat dissipation slower. The in-place concrete is able to retain more heat for a longer period of time compared to the cylinders, even if the cylinders were placed under the same curing conditions. In general, the maturity method will allow you to perform critical operations faster than the break test.

It is also possible to observe the opposite effect, where the cylinders reach the required strength while the in-place elements do not. Those cases occur more frequently in cold regions or during seasons when the cylinders might have been cured in different conditions than the structural element. An interruption to the heating system or exposure to colder temperatures would make the structural element cure slower compared to the cylinders.

6 Installation Guidelines

Once the calibration and validation are complete, maturity/temperature sensors can be installed on site to monitor in-place strength. None of the standards provide any guidelines for installation and ASTM C1074 only provides the following note: "In building construction, exposed portions of slabs and slab-column connections are typically critical locations. The advice of the engineer should be sought for critical locations in the particular structure under construction."

The following section discusses the practical points for the selection of locations and the number of maturity sensors required based on the applications in the field. When choosing a location, one must always bare in mind that colder temperatures will lead to decreased strength and vice-versa. Cylinders are made to represent the entire pour, but by using maturity, it is possible to target specific locations of the structure for temperature and in-place strength monitoring.

ACI 228. 1R, Chapter 5 - Implementation of in-place testing does propose a guideline in terms of maturity monitoring frequency in different elements. On average, it is recommended that one maturity meter be installed for every 15 m³ (20 yd³) which, based on the author's experience in the field, is somewhat overly conservative, unrealistic, and too expensive. Since there are no standards on the number of maturity probes that need to be placed in a concrete pour, a general practical guideline is proposed. Furthermore, as the maturity method is meant to eliminate the use of field-cured specimens, it is recommended to follow the same minimum requirement of one maturity reader per 100 m³ (1/150yd³)^{[26] [4]}. However, one maturity meter per 75 m³ (1/100yd³) is a typical guideline for maturity monitoring followed in the industry. It is also recommended to record maturity at a minimum of two locations in a pour. The number of measurements required is always dependent on the specific application and volume of the pour.

Concrete Maturity - From Theory to Application

In terms of where to install the sensors, there are three main questions that the engineer or the general contractor should answer:

1. Where are the critical weather locations on the structural element?

Critical weather location can be defined as the coldest and most exposed area to environmental conditions (e.g. wind, rain, etc.). Concrete will typically be colder at the corners or edges of a structure where there is less mass effect and more exposition to the ambient temperature.

2. What is the pour schedule?

In most cases, a pour can take several hours, which means that the concrete poured at the beginning and at the end does not possess the same strength as the concrete poured at the beginning since it will have started to hydrate earlier than the concrete poured at a later time. In general, a distribution of maturity sensors over the pour schedule will provide a good indication of the average strength gain. The end of the pour is a typical location for maturity monitoring since it will most likely be the location where lower in-place strength is observed.

3. Where are the structurally critical locations?

It is important for the concrete to gain sufficient strength at some critical locations in the structure before the project can move to the next phase. The critical locations can change depending on the type of structural element being monitored. More specific guidelines for typical critical locations are described in Section 6.1.

6.1. Main Applications

Depending on the type of structure, maturity might need to be monitored at different locations. This section covers the principal behind the placement of maturity meters in slabs, post-tension decks, mass concrete, and vertical elements.

6.1.1. 1-way/2-way Slabs

In one-way or two-way slab systems, the structurally critical areas are located at the larger negative and positive design moments. Typically, the maximum positive moment is located at a mid-span and maximum negative moment is located at a slab-column interface.

To illustrate a simple example for a two-way or one-way slab with unsupported span length (where $L_1 = L_2$) and uniformly distributed load, the moment distribution is usually represented

Concrete Maturity - From Theory to Application

as shown in Figure 6-1. In the case of this image, which is specific for a two-way slab system without beams, the maximum positive moment is located in the middle of the exterior span, while the maximum negative moment is located at the exterior slab-column interface for the first interior column. For a different slab configuration (slab with drop panels, beams, bands), span lengths, load patterns, and connections, the location of the maximum positive and negative moment will change. The structural engineer will be able to identify those critical locations.

The moment distribution shown in Figure 6-1 can also be visualized on a floor plan, as shown in Figure 6-2. In this case the highlighted locations (red circles) represent the locations of the maximum positive and negative moments. The maturity should be monitored in those locations considering the pour schedule and the possible colder areas.

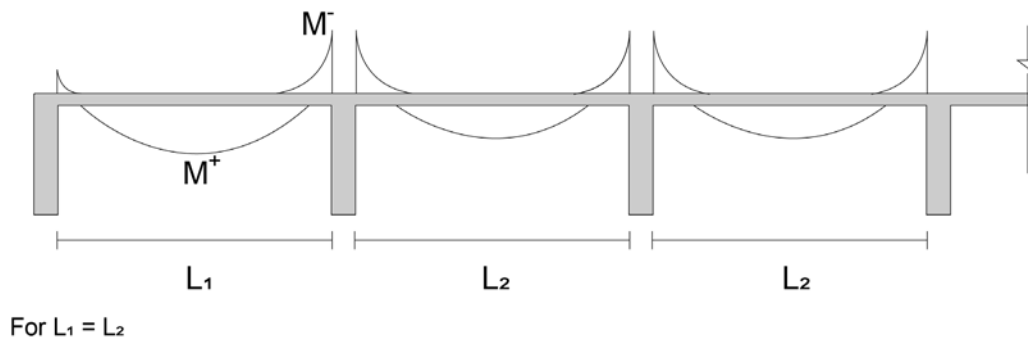

Figure 6-1: Moment distribution in 2-way slab with uniformly distributed load and constant span length.

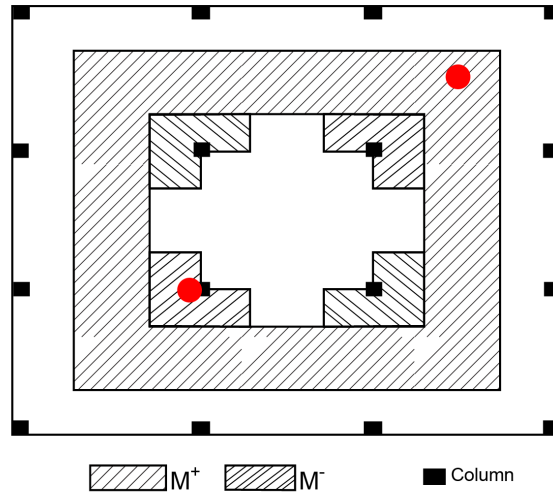

Figure 6-2: Floor plan distribution of maximum positive and negative moments presented in Figure 6-1.

For the negative moment location, the part of the concrete that is under compression is located at the bottom of the slab (or beam), and vice versa for positive moment location. Maturity should be monitored at critical compression locations as shown in Figure 6-3. Installing the sensor at the location of the nearest rebar from the top or the bottom would make the installation easier for any type of monitoring equipment.

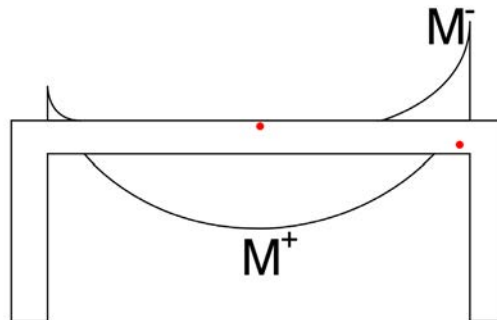

Figure 6-3: Compression locations for positive and negative moments.

6.1.2. Post Tensioning

Post tensioning is one of the most popular applications where the maturity method is used in North America. Tendons are usually tensioned as early as possible. Knowing the actual in-place strength at any given time is more cost effective than using cylinders since no time is wasted waiting for the results from the breaks. As a result, the decision to tension can be made more

Concrete Maturity - From Theory to Application

quickly. More importantly, maturity allows for the monitoring of the strength at the center and the edges of the slab or girder. When implementing post tensioning, the mid-span is usually warmer, meaning that it will reach the required strength faster.

Often the critical location becomes the edges toward the ends of the structural element (anchor location) where the temperature is cooler and the cables are located closer to the surface (stress concentration zones). Figure 6-4 represents damages to a post tensioning slab where cylinders were used for strength monitoring. In these cases, maturity could have prevented such damages. Figure 6-5 schematically represents the typical locations where maturity should be monitored on a post-tensioned deck, focusing on the edges and the maximum interior moment.



Figure 6-4: Example of damages due to early post tensioning

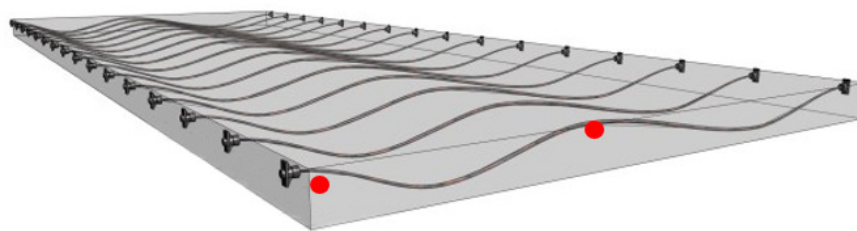

Figure 6-5: Location of maturity monitoring in post tensioning element ^[41]

Concrete Maturity - From Theory to Application

6.1.3. Mass Concrete

Due to the mass effect, the concrete core of a mass element has a high temperature compared to the surface, which is greatly affected by ambient temperature, and the bottom where heat is absorbed by the soil. Project specifications must be followed to measure the temperature at various locations. This is usually done at the center and surface, while additional measurements can be specified at the bottom and on the edges. If the difference in temperature between the core and the other locations are too large, it can cause internal thermal stress and, as a result, thermal cracking. If the tensile strength of the concrete is not high enough to withstand the thermal stress, it can cause significant cracking. The location of the temperature/maturity measurement is summarized in Figure 6-6.

The ACI 207- Mass Concrete Guideline states that the difference in temperature between the center of the element and the surface must remain smaller than 20°C (35°F) during curing. As the concrete hardens, this requirement can become conservative since it would gain enough strength to withstand larger stresses. In other cases, specifically at early age, it can lead to an overestimation of the allowable gradient. As concrete hardens, the tensile strength increases, which means that the concrete is actually able to withstand a higher temperature gradient differential as it cures. By measuring the in-place strength based on maturity, it is possible to determine the actual temperature differential allowed in order to prevent cracking. Equation 6-1 shows the simplified equation proposed by Bamforth and Crook (2006) to determine the allowable temperature difference limit.

$$\text{TemperatureDifferenceLimit}(\text{°F}) = \frac{f_t'}{E \cdot \text{CTE} \cdot R \cdot C} \quad (\text{Eq. 6-1})$$

f_t' represents the tensile strength, which can be measured at the surface of the mass element (see Figure 6-7) using the maturity method. E represents the modulus of elasticity (modulus of elasticity can also be determined through the maturity method, see section 6.2.2), R the degree of restraint, and C the creep factor, which can be taken as 1 to be conservative. The coefficient of thermal expansion (CTE) can be obtained by performing the AASHTO T336 test. Additional information on how to obtain these factors are provided in ACI 207.2R. Using maturity to determine the allowable variation in temperature in a mass pour can reduce the amount of heating or the cooling required as well as optimize the curing time.

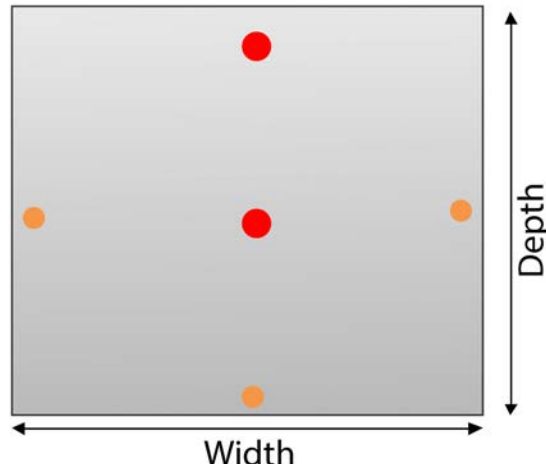
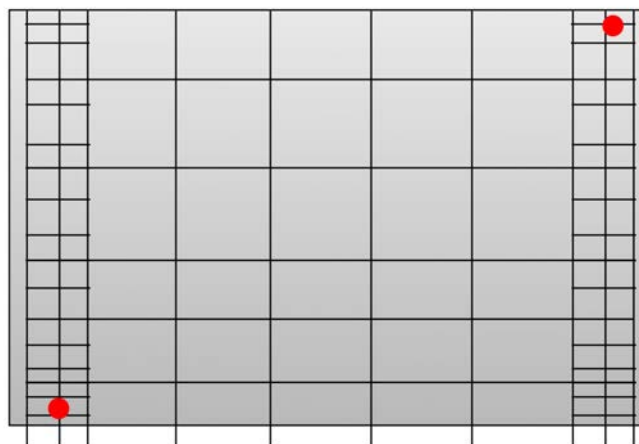

Figure 6-6: Location of temperature and maturity monitoring in mass concrete

6.1.4. Vertical Elements

Critical paths for the completion of a project are highly dependent on the completion of vertical elements such as columns and walls. A common practice is to leave walls to cure for 7 days. This approach is overly conservative. Important time savings can be gained by quickly moving on to the next construction phase. The colder area in a vertical element is at the top exposed surface for both walls and columns. Additionally, maturity monitoring needs to be done at critical locations in shear walls or columns which are located at connection areas (identified in Figure 6-7). Sometimes, large vertical elements can also be considered as mass concrete. In those cases, temperature differentials between the core and surface need to be monitored.



a) Wall

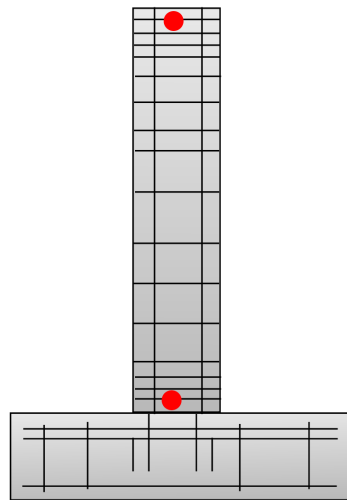

b) Column

Figure 6-7: Location of maturity monitoring in vertical elements

6.2. Other Applications

6.2.1. Pavement

One main application which can use maturity to its advantage is the paving industry. In most pavement repair cases, opening the road earlier to traffic can be beneficial. Additionally, in a lot of cases, pavement projects can be located at a far distance from the lab, which makes the transportation of the cylinders time consuming and expensive. Pavement jobs usually require high early-strength concrete where time is of the essence. Making a calibration curve to target strength in a very short period of time can allow for more precise results when compared to cylinder break tests meaning contractors are able to open the roads to traffic in a shorter time. Most departments of transportation currently approve of the maturity method to determine in-place strength.

For pavement, the location at which maturity must be monitored varies for typical structures. The location of the sensor must be based on the targeted area for early opening to traffic^[45]. Typically, maturity must be monitored in the last segment of pavement (within a certain distance from the end of the paving operation)^[44]. Other monitoring locations must be defined by the engineer and should follow the specifications from the DOT in terms of frequency of the measurement.

Concrete Maturity - From Theory to Application

6.2.2. *Modulus of Elasticity (MoE)*

The maturity method is well known and applied for compressive strength, and also frequently used to determine the flexural strength of the in-place concrete in accordance to the ASTM C1074 test method. One other application which is not standardized is the use of the maturity method to monitor the concrete modulus of elasticity. Researchers have established that the maturity method could be applied to determine the concrete MoE at early age ^{[28] [29] [33] [46]}.

6.2.3. *Precast*

The precast industry constitutes a very large amount of the concrete produced every year. Efficiency and quality control are very important factors. The National Precast Association (NPAC)^[39] and Canadian Standard Association (CSA A23.4^[27]) both require temperature monitoring to be done in precast elements. Since temperature monitoring is the base of the maturity method, using maturity would not come at a significant extra cost as it would only require calibration. Knowing the in-place strength can greatly enhance quality control and optimize the curing time.

6.2.4. *Tilt-Up*

A specific precast industry that can also benefit from the use of maturity is the tilt-up industry. In addition to compressive strength measurement, it might also be required to measure flexural strength and modulus of elasticity to avoid damages during the lifting process^[7]. Maturity calibration can be used to monitor all three properties. In other words, by monitoring the temperature and maturity of the tilt-up element, the flexural and compressive strength, and MoE can easily be obtained without the need for testing additional cylinders and beams. It would also provide additional benefits to the quality control practice and the amount of curing required. Maturity in tilt-up application is gaining more and more popularity in the industry.

6.2.5. *Shotcrete*

Shotcrete is usually used in hard-to-access areas, where having the appropriate strength is crucial, such as mining applications. In this case, maturity can be used to improve quality control and potentially reduce the cost of the core-drilled cylinder breaks taken from the panel test. The same step as described in the calibration must be done. The only difference is that instead of casting cylinders for the calibration, cores from panels must be taken according to ASTM D1140^[21] and the temperature measurement for calibration must be taken from the center of the panel. Special attention would need to be directed to the dry-batch shotcrete as the nozzle operator is the element in charge of controlling the amount of water in the mix. Additionally, larger variance could be expected between the calibrated mix and the in-place concrete.

7 Economic Benefits

There are significant economic benefits to using maturity on a construction project. Cost savings are not only observed on large projects, small projects can gain from the use of this method. The main advantages of using the maturity method have been described in previous chapters. Overall, significant advantages can be seen through the ability to save time by conducting critical operations more efficiently, such as removing formwork, post tensioning, and opening pavement to traffic in a more efficient and timely manner. In every industry, particularly the construction industry, time is money.

There are initial costs associated with the use of maturity which include the maturity meters and calibration. However, there are more important cost savings that can result from the implementation of this method. Table 7-1 shows a breakdown of the initial cost involved in the implementation of the maturity method and possible cost savings on a project. The price ranges given are subject to change based on the type of maturity meter and the quantity of maturity meters/sensors purchased. Additionally, the cost of cylinders and site operation varies greatly depending on the location and type of project. As there are significant differences in terms of pricing between different maturity meters on the market, the cost of maturity was averaged and taken as an additional cost per concrete volume. Using the values presented in Table 7-1 as an example of a return on investment (ROI) calculation is presented in Table 7-2. All prices presented in Table 7-1 and Table 7-2 are shown in \$USD and represent an average of the cost in the American market.

Table7-1: Breakdown of maturity and saving costs

Maturity cost		
Cost of maturity monitoring	\$2/m ³	Average cost including; data logger, licence fees, installation, and data analysis.
Cost of calibration	\$1,500 - \$2,500	For one mix
Cost savings		
Conventional field -cured break test per pour	\$600- \$1,200	Including sampling, pick up, delivery, testing and reporting
Cost of delays per day	\$ 10,000 - \$ 15,000	Cost for a general contractor to have a job site up and running: including labour and equipment.
Average cost of coring	\$ 300-\$800	Often, coring is required because of the bad break result from the lab.
Cost of unnecessary heating/cooling	--	This cost is specific to the project, location and season.
Financing cost savings after project completion	--	Bonus or penalties.

All values provided in this table were obtained through the experience of the authors and customer testimonials. Those values are subject to changes depending on the market.

Table7-2: Example of ROI Calculation

ROI EXAMPLE	
Maturity cost	
Total concrete volume for the project	4,000 m ³
Total cost of maturity monitoring for the project	\$8,000
Cost of calibration (one mix)	\$2,000
Total cost for maturity	\$10,000
Cost savings	
Number of pours in the project	20
Average cost for conventional field-cured break test per pour	\$900
Total cost of cylinders	\$18,000
Total days in delay of formwork removal for the entire project (assuming ½ day per pour)	10 days
Total cost of delay (assuming \$10,000 per day)	\$100,000
Cost of additional coring	\$0
Cost of heating	\$0
Bonus	\$0
Total cost savings	\$118,000
ROI	1080%

Concrete Maturity - From Theory to Application

In the above example, typical average values were used and cost savings were conservative. The reader is encouraged to develop his/her own ROI to gain a better understanding of the cost savings based on the specifics of his/her own project⁴. To put things into perspective, looking at the specific example shown in Table 7-2, if the time savings are as small as one day for the entire duration of the project, the cost of maturity is already offset. The following chapter provides case studies of projects where maturity has been used as an alternative to field-cured specimens and where important time and cost savings have been observed.

⁴ For a rapid and easy ROI calculation visit <https://www.giatecscientific.com/roi-calculator/>

8 Case Studies

An in-depth understanding of the maturity concept has many practical and economical benefits for the construction industry. The maturity method, in conjunction with sensors, produces more accurate data when compared to break tests and other monitoring methods. Currently, wired concrete sensors are the most widely used tool for measuring concrete temperature and strength. However, there are many challenges associated with the use of these devices. This includes accidental cutting of wires, expensive data logger equipment, issues with wire crossover, and more. As a result, new technology is being introduced to combat these possible issues.

In particular, Giatec, among other companies, has released a wireless sensor for measuring and monitoring temperature and maturity of concrete. Giatec's SmartRock is a rugged wireless sensor that allows for the collection of data remotely. The sensor is installed on the rebar, directly on the concrete formwork, before pouring. Using the accompanying mobile app, the temperature, resulting concrete strength, and maturity can be viewed in real-time. In this way, any team member with a smart device can instantly share this data. With the continuous concrete temperature monitoring, concrete strength and maturity is automatically calculated. This allows for more efficient scheduling of construction operations, such as formwork removal, saving both time and money during a project. Please find below some case studies in which Giatec's SmartRock sensors were instrumental in the success of a project.

Concrete Maturity - From Theory to Application

Flood Testing Laboratories Inc. Chicago, Illinois

Flood Testing Laboratories (FTL) is a family run business with extensive experience in construction materials testing. The maturity method for predicting concrete strength is a core capability and area of specialization for FTL, allowing them to provide construction material testing services to clients throughout the Chicago area.

Some of the challenges faced by FTL during their construction projects were; the high costs of wired sensor readers, complications resulting from wire-management, vulnerability of wires on site, and an inability to access data remotely and share that data with project team members.

As a solution, FTL implemented Giatec Scientific's SmartRock sensors for wireless, real-time monitoring of concrete maturity in their project. These sensors, attached to the rebar, are installed on the formwork and used to calculate maturity and strength based on the ASTM C1074 standard. With the use of these sensors, FTL eliminated issues regarding exposed or hard-to-access wiring. Additionally, the use of Giatec's technology allowed them to remotely access and share data in real-time and on any smart mobile device, without the need for any specialized equipment, greatly improving communication with all their team members. As a result, FTL was able to optimize their project schedule, formwork removal, and post tensioning.

Read more about Flood Testing Laboratories Inc.'s experience with Giatec's SmartRock Sensors here:

<https://www.giatecscientific.com/case-study/flood-testing-laboratories-inc/>

Concrete Maturity - From Theory to Application

Divcon Inc. Spokane Valley, Washington

Divcon Inc., a full-service general contractor, relied on wired sensors to monitor concrete strength and maturity in the field. Frustrated with mislabelled wires, accidental cutting of wires, damage to sensors, and errors in reading data caused by wire cross-over, they switched to a more reliable way to monitor the maturity of concrete in the field using Giatec's SmartRock sensors.

Adopting the technology for a 40,000 square foot elevated post tension podium slab deck, they tagged 18 sensors around the entire perimeter of the slab's frame. Once installed, the team was able to connect to the sensors and receive real-time temperature, strength, and maturity measurements directly to on their phones. This data was accessed and shared instantly, allowing for fast and informed decision making on site.

When compared to cylinder break tests, maturity sensors provided more accurate and consistent results, thereby ensuring the complete safety and integrity of the concrete Divcon was delivering.

Read more about Divcon's project here:
<https://www.giatecscientific.com/case-study/divcon-inc/>

Concrete Maturity - From Theory to Application

Graham Construction Calgary, Canada

Frank Hoffmann, superintendent of Graham Construction, ran a side-by-side comparison of regular thermocouples and Giatec's wireless SmartRock concrete sensors for real-time temperature monitoring during the construction of a \$130 million, 350,000 square foot transit facility for the city of Edmonton.

The switch to Giatec's technology came about from a frustration with the inefficiencies of thermocouples, such as wires which were prone to damage, and the need for expensive data loggers to collect and read results which were time-consuming and labor-intensive. With the ability of the SmartRock sensor to provide the most accurate in-situ concrete temperature and maturity data, it consistently achieved a 90% accuracy in maturity-based strength estimation when compared to standard concrete cylinder breaks.

As a result, Hoffmann was able to cut costs due to the elimination of the need for a technician to visit the jobsite every eight hours to plug into each and every thermocouple, record the temperatures, and go back to the office to save and analyze the data. Furthermore, time was saved through the use of the SmartRock app and its' ability to share data automatically.

Read more about Graham Construction's use of SmartRock sensors here:
<https://www.giatecscientific.com/case-study/graham-construction/>

Concrete Maturity - From Theory to Application

S&F Concrete Contractors Hudson, Massachusetts

During the construction of the 28-storey Wynn Hotel and Casino in Boston, Massachusetts, S&F Concrete Contractors needed an accurate temperature monitoring system that would also be able to provide reliable concrete strength data.

Project manager Steve Pirrello saw promise in Giatec's SmartRock sensors and their ability to accurately measure concrete maturity and strength, without the hassle of time-consuming lab testing and concrete cylinder breaks.

Before any work started, the project engineers ran tests comparing the SmartRock sensor data to the results of the cylinder breaks. Repeatedly, they found that the maturity meters provided similar, if not more accurate results, than the lab break tests. As such, the engineers felt confident enough to eliminate early break tests. The S&F team noted that they were more comfortable relying on the sensor readings, rather than concrete cylinders, which they found had too many variables and inaccuracies. Relying solely on SmartRock sensor data, the S&F team was able to schedule tensioning of slabs within an hour of the concrete achieving the required strength, instead of waiting a minimum of 24 hours for break test results.

Read more about S&F Concrete Contractor's experience with Giatec's SmartRock sensors here: <https://www.giatecscientific.com/case-study/sf-concrete-contractors/>

Concrete Maturity - From Theory to Application

Gilchrist Construction Company Alexandria, LA

During the construction of a bridge, Gilchrist Construction (GC) significantly saved time and money through the use of Giatec's SmartRock wireless sensors. In using SmartRock sensors, the Gilchrist team was able to reduce labor-intensive work by minimizing the need for break tests. The biggest setback, according to project manager Frank Maury, was the need to conduct initial maturity calibration tests necessary for the use of the sensors themselves. However, they are hoping to avoid such delays by working on future projects with Angelle Materials, a ready-mix producer and Giatec SmartRock Plus partner in Baton-Rouge, in order to benefit from pre-calibrated mixes. This will eliminate the task of performing their own calibrations. With bridgework starting in March 2017, GC was able to open the bridge to traffic by October of the same year.

Read more about Gilchrist Construction (GC) use of Giatec's SmartRock Sensors and to learn about SmartRock Plus here:

<https://www.giatecscientific.com/case-study/gilchristconstruction-company/>

9 References

- [1] AASHTO T325-04, Standard Method of Test for Estimating the Strength of Concrete in Transportation Construction by Maturity Tests, American Association of State Highway and Transportation Officials, Washington, D.C 2004
- [2] AASHTO T336-15, Coefficient of Thermal Expansion of Hydraulic Cement Concrete, American Association of State Highway and Transportation Officials, Washington, D.C 2015
- [3] ACI Committee 228.2R-13, Report on Non-destructive Test Methods for Evaluation of Concrete in Structures. American Concrete Institute, Farmington Hills, Michigan, 2013.
- [4] ACI Committee 318-14, Building Code Requirements for Structural Concrete and Commentary. American Concrete Institute, Farmington Hills, Michigan, 2014.
- [5] ACI Committee 306R-16, Guide to Cold Weather Concreting. American Concrete Institute, Farmington Hills, Michigan, 2016.
- [6] ACI Committee 207.2R-07, Report on Thermal and Volume Change Effects on Cracking of Mass Concrete. American Concrete Institute, Farmington Hills, Michigan, 2007.
- [7] ACI Committee 551.1R-14, Guide to Tilt-Up Concrete Construction. American Concrete Institute, Farmington Hills, Michigan, 2014.
- [8] ASTM C31 / C31M-18a, Standard Practice for Making and Curing Concrete Test Specimens in the Field, ASTM International, West Conshohocken, PA, 2018, www.astm.org
- [9] ASTM C39 / C39M-18, Standard Test Method for Compressive Strength of Cylindrical Concrete Specimens, ASTM International, West Conshohocken, PA, 2018, www.astm.org
- [10] ASTM C42 / C42M-18, Standard Test Method for Obtaining and Testing Drilled Cores and Sawed Beams of Concrete, ASTM International, West Conshohocken, PA, 2018, www.astm.org
- [11] ASTM C109 / C109M-16a, Standard Test Method for Compressive Strength of Hydraulic Cement Mortars (Using 2-in. or [50-mm] Cube Specimens), ASTM International, West Conshohocken, PA, 2016, www.astm.org

Concrete Maturity - From Theory to Application

- [12] ASTM C494 / C494M-17, Standard Specification for Chemical Admixtures for Concrete, ASTM International, West Conshohocken, PA, 2017, www.astm.org
- [13] ASTM C511-13, Standard Specification for Mixing Rooms, Moist Cabinets, Moist Rooms, and Water Storage Tanks Used in the Testing of Hydraulic Cements and Concretes, ASTM International, West Conshohocken, PA, 2013, www.astm.org
- [14] ASTM C597-16, Standard Test Method for Pulse Velocity Through Concrete, ASTM International, West Conshohocken, PA, 2016, www.astm.org
- [15] ASTM C803 / C803M-17, Standard Test Method for Penetration Resistance of Hardened Concrete, ASTM International, West Conshohocken, PA, 2017, www.astm.org
- [16] ASTM C805 / C805M-13a, Standard Test Method for Rebound Number of Hardened Concrete, ASTM International, West Conshohocken, PA, 2013, www.astm.org
- [17] ASTM C873 / C873M-15, Standard Test Method for Compressive Strength of Concrete Cylinders Cast in Place in Cylindrical Molds, ASTM International, West Conshohocken, PA, 2015, www.astm.org
- [18] ASTM C900-15, Standard Test Method for Pullout Strength of Hardened Concrete, ASTM International, West Conshohocken, PA, 2015, www.astm.org
- [19] ASTM C918 / C918M-13, Standard Test Method for Measuring Early-Age Compressive Strength and Projecting Later-Age Strength, ASTM International, West Conshohocken, PA, 2013, www.astm.org
- [20] ASTM C1074-17, Standard Practice for Estimating Concrete Strength by the Maturity Method, ASTM International, West Conshohocken, PA, 2011, www.astm.org
- [21] ASTM D1140-17, Standard Test Methods for Determining the Amount of Material Finer than 75- μ m (No. 200) Sieve in Soils by Washing, ASTM International, West Conshohocken, PA, 2017, www.astm.org
- [22] Bergstrom, S. G., "Curing Temperature, Age and Strength of Concrete", Magazine of Concrete Research, Vol. 5, No. 14, 1953, pp. 61-66.
- [23] BS EN 13670, Execution of concrete Structures, British Standard Institution, London, United Kingdom, 2009
- [24] Carino, N. J. [1984], "The Maturity Method: Theory and Application", Cement, Concrete and Aggregates, Vol.6, No. 2, 1984, pp. 61-73.
- [25] Compressive Strength Test on Concrete Core- Calculation and Results. The constructor. <https://theconstructor.org/practical-guide/compressive-strength-test-on-concrete-core/7581/>. Accessed March, 2018.
- [26] CSA Standard A23.1-14/A23.2 -14, Concrete materials and Methods of Concrete Construction/ Test Methods and Standard Practices for Concrete, Canadian Standard Association, 2014

- [27] CSA Standard A23.4, Precast Concrete-Materials and Construction, Canadian Standard Association, 2016
- [28] Delsaute. B. et al., Testing Concrete E-modulus at very Early Ages through Several Techniques: AN Inter-laboratory Comparison strain: an international Journal for Experiment Mechanics, Volume 52, Issue 2, 2016, p.91-109
- [29] Ferraro C. Determination of Test Methods for the Prediction of the Behavior of Mass Concrete. [PhD thesis]. Gainesville, FL: University of Florida ; 2009, 277
- [30] Guo, C., "Maturity of Concrete: Method for Predicting Early-Stage Strength", ACI Materials Journal, Vol. 86, No. 4, July-August 1989, pp. 341-353.
- [31] Han.N. Maturity Method. Advanced Testing of Cement-Based Materials During Setting and Hardening. Report of RILEM Technical committee 185-ATC. RILEM Publication S.A.R.L, France, 2005, pp. 277-296
- [32] Hansen, P. F. and Pedersen, E. J., "Maturity Computer for Controlled Curing and Hardening of Concrete," Nordisk Betong, Vol. 1, 1977, pp. 21-25.
- [33] Kehl R.J. and Carrasquillo R.L. Investigation of the Use of Match Cure Technology in the Precast Concrete Industry. Center for transportation Research Bureau of Engineering Research, University of Texas at Austin, 1998.
- [34] Lee, C. H. and Hover, K. C., "Influence of Datum Temperature and Activation Energy on Maturity Strength Prediction," ACI Mater. J., Vol. 112, No. 6, 2015, pp. 781-790.
- [35] Lee, C. H. and Hover, K. C., "Relationship between Computed Rate Constants and the Variability in Maturity-Based Strength Predictions," Journal of Testing and Evaluation <https://doi.org/10.1520/JTE20160181>. ISSN 0090-3973
- [36] McIntosh, J. D., "Electrical Curing of Concrete", Magazine of Concrete Research, Vol. 1, No. 1, 1949, pp. 21-28.
- [37] NCH 170, concrete- General requirements, Institution Nacional de Normalizacion -Inn Chile, Santiago, Chile, 2016 (in Spanish)
- [38] NEN 5970, Determination of strength of fresh concrete with the method of weighted maturity, Netherlands Standard Institute, Delft, Netherlands, 2001, www.nen.nl
- [39] NPCA Quality Control Manual for Precast Concrete Plants, 13th Edition, National Precast Concrete Association, Carmel, IN, 2018, www.precast.org
- [40] Nurse, R. W., "Steam Curing of Concrete", Magazine of Concrete Research, Vol. 1, No. 2, 1949, pp. 79-88.
- [41] Post Tension Structure in Revit. Håvard Vasshaug. <https://vasshaug.net/2013/02/27/post-tension-structures-in-revit/>, Accessed on May 2018.
- [42] Saul, A. G. A. , "Principles Underlying the Steam Curing of Concrete at Atmospheric Pressure", Magazine of Concrete Research, Vol. 2, No. 6, 1951, pp. 127-140.

Concrete Maturity - From Theory to Application

- [43] Skyline Tower Collapse. Wikipedia. https://en.wikipedia.org/wiki/Skyline_Towers_collapse. Accessed on March,2018.
- [44] Standard specifications for Road and Bridge Construction. Colorado Department of Transportation (CDOT), Denver, CO, 2011, www.codot.gov
- [45] Standard specifications for Construction and Maintenance of Highways, Streets and Bridges. Texas Department of Transportation (TxDOT), Austin, TX, 2004, www.codot.gov
- [46] Waller. V et al., "Using the maturity method in concrete cracking control at early ages". Cement and concrete composites, Volume 26, Issue 5, 2004, p.589-599
- [47] World and U.S cement production 2010-2017. Statistica. <https://www.statista.com/statistics/219343/cement-production-worldwide/>. Accessed on March 2018.



Giatec Scientific Inc. is a global company revolutionizing the construction industry by bringing smart concrete testing technologies and real-time data collection to the forefront of every jobsite. Giatec has leveraged advanced technologies such as; Artificial Intelligence (AI), and Internet of Things (IoT) solutions, including; wireless concrete sensors, mobile apps, and advanced non-destructive technologies (NDT) to drive innovation throughout concrete's lifecycle. Giatec's vision is to create knowledge and wisdom within a conservative industry by addressing the current challenges in concrete testing, analysis, design, and production. Our strength lies in our experts who have a robust understanding of the industry and solve engineering problems by using the most recent research and technological tools. Giatec's industry award-winning products have been used in over 5,200 products across 80 countries helping companies build concrete structures faster, safer, and more economically.

For more information, visit
www.giatec.ca

CONNECT WITH US

✉ info@giatec.ca
☎ Toll-Free: +1 (877) 497-6278

in [linkedin.com/company/giatec-scientific](https://www.linkedin.com/company/giatec-scientific)
t twitter.com/Giatec
f facebook.com/giatec/

